

**RULES AND REGULATIONS
FOR
WATER AND WASTEWATER SERVICE**



**EAGLE RIVER
WATER & SANITATION
DISTRICT**

**APPENDIX D
STANDARD SPECIFICATIONS FOR
WASTEWATER MAINS**

Last Approved Revision: February 22, 2024

TABLE OF CONTENTS

SECTION I – GENERAL REQUIREMENTS	5
1.1 Authority	5
1.2 Effective Date of Specifications	5
1.3 Revisions, Amendments, or Additions	5
1.4 Definitions.....	5
1.5 Development Approval and Infrastructure Acceptance	5
1.6 Variance	5
SECTION II – COLLECTION SYSTEM DESIGN AND LAYOUT	6
2.1 General Requirements.....	6
2.2 Corrosion.....	6
2.2.1 Dissimilar Materials.....	6
2.2.2 Insulating Joints	6
2.3 Sizing Collection Mains.....	6
2.4 Layout of the Collection System	7
2.4.1 Easement Width Requirements for Main Installations	7
2.4.2 Minimum Size	8
2.4.3 Depth of Bury.....	8
2.4.4 Main Insulation Requirements.....	8
2.4.5 Minimum Distance from Structures	8
2.4.6 Installations in High Groundwater	9
2.5 Slope of Wastewater Mains	9
2.5.1 Minimum Slopes	9
2.5.2 Maximum Slopes	9
2.5.3 Slope between Manholes.....	10
2.5.4 Steep Slope Applications	10
2.5.5 Slope across Manholes.....	10
2.5.6 Main Line Horizontal Alignment	10
2.5.7 Length of Mains and Slope Measurement.....	10
2.5.8 Manholes	10
2.5.9 Manhole Clearances	11
2.5.10 Manhole Connections	12
2.5.11 Location/Marking Tape	12
2.5.12 Pipe Material	12
2.5.13 Lift Stations	12
2.5.14 Maintenance Access.....	12
2.6 Protection of Potable Water Supplies	12
2.6.1 Cross Connections Prohibited.....	12
2.6.2 Relation to Water Works Structures	13
2.6.3 Separation of Infrastructure.....	13
SECTION III – MATERIAL SPECIFICATIONS	15
3.1 General Requirements.....	15
3.2 Pipe and Fittings.....	15
3.2.1 Polyvinyl Chloride (PVC) gravity pipe.....	15
3.2.2 Polyvinyl Chloride (PVC) pressure pipe	15

3.2.3	Ductile Iron Pipe (DIP)	16
3.2.4	Service Line Taps	16
3.2.5	Transition Adapter	16
3.3	Manholes	16
3.3.1	Manhole	16
3.3.2	Water Tightness	16
3.3.3	Rings and Covers	16
3.3.4	Grade Rings	17
3.3.5	Manhole steps	17
3.3.6	Joint Sealant	17
3.3.7	Pipe to Manhole Seal	17
3.3.8	Flow Channel	18
3.3.9	Bench	18
3.3.10	Manhole Base	18
3.3.11	Interior Coatings	19
3.4	Concrete/Grout	19
3.4.1	General Requirements	19
3.4.2	Concrete	19
3.4.3	Mortar and Grout	19
3.5	Locating Disk	19
3.6	Marking Tape	19
3.7	Casing Material and Spacers	20
3.8	Tracer Wire (REQUIRED)	20
SECTION IV – PIPE INSTALLATION & CONSTRUCTION		21
4.1	Safety	21
4.2	Handling of Materials	21
4.3	Inspection and Preparation of Pipe and Fittings	21
4.4	Cutting and Fitting of Pipe	21
4.5	Pipe Alignment and Grade	22
4.6	Temporary Plugs	22
4.7	Frost	22
4.8	Lowering of Material into the Trench	22
4.9	Installation of Pipe	23
4.9.1	General Requirements	23
4.9.2	Ductile Iron Pipe	23
4.9.3	Polyvinyl Chloride Pipe	24
4.9.4	Yelomine Pipe	24
4.9.5	Job-Mixed Concrete	24
4.9.6	Ready-Mixed Concrete	24
4.10	Manholes	24
4.11	Service Lines	25
SECTION V – TESTING AND ACCEPTANCE		26
5.1	General Requirements for Connections	26
5.1.1	Service Connections	26
5.1.2	Connections to Manholes	26
5.2	Testing – Wastewater Mains	26
5.2.1	Alignment	26
5.2.2	Low Pressure Air Testing – General Requirements	26
5.2.3	Low Pressure Air Testing Procedure	26

5.3	Manhole Testing – General Requirements.....	28
5.3.1	Manhole Testing Procedure.....	28
5.4	Television Inspection – General Requirements.....	29
5.4.1	Inspection Format.....	29
5.4.2	CCTV Video Content.....	30
5.4.3	District Review.....	30
5.4.4	Correction of Deficiencies.....	30
5.5	Wastewater Main Repairs.....	30
5.6	Protection of Existing Wastewater System.....	30
5.7	Manhole Abandonment.....	31
5.8	Wastewater Main Abandonment.....	31
5.8.1	Wastewater Main With Manhole Connection Abandonment.....	31

SECTION VI – STANDARD FORMS AND DETAILS 32

FORM D1:	PRE-CONSTRUCTION MEETING CHECKLIST FOR SEWER MAIN INSTALLATION.....	32
FORM D2:	SEWER SYSTEM ACCEPTANCE PROCEDURE.....	32
FORM D3:	SEWER PIPE CLEANING AND TELEVISIONING CUT SHEET.....	32
FORM D4:	BILL OF SALE – SEWER MAIN.....	32
FORM D5:	SEWER EASEMENT.....	32
FORM D6:	LENDER’S CONSENT.....	32
EXAMPLE SPECIFICATION D1:	WASTEWATER FLOW MANAGEMENT PLAN.....	32
EXAMPLE SPECIFICATION D2:	DISCHARGE EMERGENCY RESPONSE PLAN.....	32
D-01:	STANDARD MANHOLE.....	32
D-02:	DROP MANHOLE.....	32
D-03:	BAR SCREEN MANHOLE.....	32
D-04:	ANCHOR MANHOLE.....	32
D-05:	CASING DETAIL.....	32
D-06:	SEWER MAINTENANCE ACCESS.....	32
D-07:	GROUNDWATER BARRIER.....	32
D-08:	ARM DESIGN TURNAROUND.....	32
D-09:	EASEMENT WIDTH DETAIL.....	32
D-10:	SEWER PIPE INSULATION DETAIL.....	32
D-11:	WATER AND WASTEWATER SEPARATION.....	32
D-12:	DEAD END MANHOLE.....	32

SECTION I – GENERAL REQUIREMENTS

1.1 Authority

The Standard Specifications for Wastewater Mains (the “Specifications”) are promulgated by the Eagle River Water & Sanitation District (“District”). The interpretation and enforcement of the Specifications is hereby delegated to the District Regulations Administrator.

1.2 Effective Date of Specifications

The Specifications shall become effective immediately upon formal adoption by the District and shall supersede all former specifications for wastewater main construction. The most current version of these Specifications is available at www.erwsd.org.

1.3 Revisions, Amendments, or Additions

The Specifications may be revised and/or amended. Such revisions, amendments, and additions shall be binding and in full force immediately upon formal adoption by the District.

1.4 Definitions

Please reference the Rules and Regulations for Water and Wastewater Service, Article II.

1.5 Development Approval and Infrastructure Acceptance

Please reference the Rules and Regulations for Water and Wastewater Service, Articles VIII and IX, respectively.

1.6 Variance

The District recognizes that the strict and literal interpretation of these Rules and Regulations may not be possible in all cases. Please refer to Article VII for information on the Variance process.

SECTION II – COLLECTION SYSTEM DESIGN AND LAYOUT

2.1 General Requirements

The District requires an Overall Utility Site Plan of the project to be submitted indicating all utilities and their proposed locations for review prior to Construction Plan Approval. All plans submitted shall include a geotechnical report if requested by the District. The design and installation of all facilities shall ensure development of an integrated collection system. All buried pipe lines shall be electronically locatable with a tracer wire system as specified in Appendix E.

2.2 Corrosion

Corrosive soils are present in the District's service area and may lead to the premature degradation of pipe materials and appurtenances. Please refer to Article IX for corrosive soils procedure.

2.2.1 Dissimilar Materials

Cathodic protection and insulation shall be installed as required by the District. Particular care shall be taken to insulate between dissimilar materials.

2.2.2 Insulating Joints

Whenever it is necessary to join pipe of dissimilar metal, or when designated by the District, a method of insulating against the passage of electrical current, approved by the District, shall be provided. Special care shall be exercised during the installation of these joints to prevent electrical conductivity across the joints.

2.3 Sizing Collection Mains

All mains shall be sized to collect and convey estimated peak wastewater flows of the ultimate population of the tributary area to be served. The applicant shall submit a Basis of Design Report (BDR) prepared by a registered professional engineer that includes a hydraulic evaluation of the collection system. Application of peer-reviewed hydraulic principles shall be used in the preparation of the BDR. ERWSD recognizes the most current versions of the following as the primary sources of hydraulic principles for use in design of interceptors and wastewater mains:

1. Gravity Sanitary Sewer Design and Construction, published as American Society of Civil Engineers (ASCE) Manuals and Reports on Engineering Practice No. 60 and Water Environment Federation (WEF) Manual of Practice No. FD-5 (MOP FD-5), latest edition.

SECTION III – MATERIAL SPECIFICATIONS

2. Manning's Equation; unless conditions require or are best addressed with other methods referenced in MOP FD-5.
3. CDPHE-State of Colorado Design Criteria for Domestic Wastewater Treatment Works. (CDC-DWTW)

Peak design flow rates shall be reported, based on average per SFE wastewater generation rates, a peaking factor, and shall include flow from inflow and infiltration (I&I). The minimum wastewater generation rate shall be 195 gpd/SFE inclusive of I&I. Alternative design standards for wastewater generation by development type that are submitted with documentation will be considered by the District on a case by case basis. Hydraulic design parameters shall be documented in the BDR including:

1. Hydraulic design shall be based upon a Manning's Formula, using a Roughness Coefficient or 'n' value of 0.013.
2. Wherever possible, all mains shall be designed to give mean velocities, when at average annual daily flow, of not less than two feet per second (2 fps) to insure self-cleaning, and maximum velocities of not more than ten feet per second (10 fps). While minimum velocities are priority, where the minimum is unobtainable due to site constraints, reference table D-1 for minimum slopes that may be allowed at District's discretion.
3. Peaking Factor per CDC-DWTW guidance pdf Figure 3.1
4. Initial operating conditions may not provide for conditions to attain a flow velocity of 2 fps at annual average daily flow. In this case, the flow velocity at peak hour flow must be analyzed. If the initial peak hour flow velocity is 2 fps or greater, the minimum flow velocity criteria is satisfied.

If initial operating conditions do not provide for conformance with the minimum flow velocity criteria at average daily flow or peak hour flow, written acknowledgement shall be provided to the ERWSD. Design conditions shall provide for maximum depth of flow at peak hour flow rate of no more than 80 percent of the internal pipe diameter (i.e., d/D). Full pipe design conditions shall not be allowed, except for siphons which require full pipe flow. The District reserves the right to request oversized mains to provide service for projected future needs. The additional cost for the oversizing may be negotiated between the District and the Applicant and will be reviewed on a case-by-case basis.

2.4 Layout of the Collection System

2.4.1 Easement Width Requirements for Main Installations

All mains shall be installed in dedicated public street rights-of-way, when ROW installation is not possible, a dedicated wastewater line easement will be required. The installation of Public Wastewater facilities on developable lots or tracts intended for

private use should be avoided to the extent practicable. The standard easement width for all mains shall be a minimum of 20 feet. The main shall be generally centered within the easement. The easement width shall be in accordance with Standard Detail D-09.

2.4.2 Minimum Size

All mains shall be a minimum of eight inches (8") in diameter. All Wastewater Service Lines shall be a minimum of four inches (4") in diameter, Refer to Appendix B for Wastewater Service Line Construction Specifications.

2.4.3 Depth of Bury

In general, mains are to be sufficiently deep to receive wastewater from basements and to prevent freezing. The minimum cover above a main shall be four feet six inches (4'-6"). For every foot of cover that is out of compliance with minimum cover requirements, the District will require the installation of 1-inch of insulation board per Appendix E Section 1.14. The absolute minimum cover over a wastewater main is 3'. Wastewater Service Line connections are not permitted in areas where there is less than 4'6" cover over the Wastewater Main. In addition to maintaining cover from the ground surface, specified cover is required from storm sewer crossings and other cold air sources. Additional depth may be required to allow for adequate cover on service lines. The Applicant shall demonstrate that the pipe materials are suitable for the proposed depth of installation. Any main installation greater than ten feet (10') shall require an increased wall thickness. Any proposed main installation greater than 14 feet (14') shall require an alternatives analysis submittal and District approval.

The maximum depth for a wastewater manhole is fourteen feet (14') and shall be measured from the top of rim to the downstream invert. Any proposed applications with manholes installed at a depth greater than fourteen feet (14') shall require an alternatives analysis submittal and District approval.

2.4.4 Main Insulation Requirements

For every foot of cover that is out of compliance with minimum cover requirements, the District will require the installation of 1-inch of insulation board per Appendix E Section 1.14. In addition to maintaining cover from the ground surface, specified cover is required from storm sewer crossings and other cold air sources.

2.4.5 Minimum Distance from Structures

All main extensions shall be installed at a minimum distance of ten feet (10') from all structures or at a one foot horizontal to one-foot vertical (1:1) ratio from the bottom of any structural element, whichever is greater. Encroachments of structures into easements are discouraged and shall only be allowed by written authorization from the District.

2.4.6 Installations in High Groundwater

Installations in areas of high groundwater, as determined in the soils/geotechnical report, may require the following special provisions and evaluated on a case-by-case basis:

- (a) Groundwater barriers, in order to prevent transmission of groundwater along the pipe bedding (See Standard Detail D-07).
- (b) Use of C-900 or Yelomine pressure rated piping and joints
- (c) Engineered design to prevent floatation of the main due to buoyant forces
- (d) High groundwater manholes as identified in 3.3.2

2.5 Slope of Wastewater Mains

2.5.1 Minimum Slopes

All Wastewater Mains shall be designed and constructed to give mean velocities per section 2.3. The following are the required minimum slopes for Wastewater Mains 42 inches or less. However, slopes greater than these are desirable. If proposed slopes that are at or near the specified minimum, the District may require an increased slope to control wastewater gases and/or to maintain self-cleaning velocities. See Table D-1 Minimum and Maximum Wastewater Main Slopes.

2.5.2 Maximum Slopes

The maximum slope allowable in pipeline design will be based upon 10 feet per second maximum velocity. Lined pipes may be able to resist scour at high velocities, however, undue turbulence can become an over-riding design consideration as unacceptable levels of odors may be produced from hydrogen sulfide generation. See Table D-1 Minimum and Maximum Wastewater Main Slopes.

Table D-1: Minimum and Maximum Wastewater Main Slopes

Pipe Diameter (Inches)	Minimum Slope (Feet per 100 linear feet)	Maximum Slope (Feet per 100 linear feet)
8 inches	0.70	6.48
10 inches	0.28	4.82
12 inches	0.22	3.84
14 inches	0.17	3.08
15 inches	0.15	2.81
16 inches	0.14	2.58
18 inches	0.12	2.20
21 inches	0.10	1.79
24 inches	0.08	1.50

SECTION III – MATERIAL SPECIFICATIONS

27 inches	0.067	1.29
30 inches	0.058	1.11
33 inches	0.052	0.98
36 inches	0.046	0.87
39 inches	0.041	0.79
42 inches	0.037	0.71

2.5.3 Slope between Manholes

A continuous slope shall be maintained on main installations between manholes. Manholes are required at every slope change of the main.

2.5.4 Steep Slope Applications

Steep slope applications with mains longer than 100 feet (100') are required to install a bar screen manhole at the top of the slope per Detail D-03. Grade breaks shall not be permitted in manholes in excess of ten percent (10%) at the bottom of steep slope applications. Mains shall be anchored securely to the manhole and installed with restrained joint connections per Detail D-04. Wastewater mains with slopes of twenty percent (20%) or greater shall require restrained joints to be designed by the Engineer.

2.5.5 Slope across Manholes

The minimum fall across a standard manhole shall be two-tenths of a foot (0.2'). The hydraulic grade line and energy grade line of flow in a manhole shall be designed to stay below the crown of the pipe.

2.5.6 Main Line Horizontal Alignment

All mains shall be installed with a straight horizontal alignment between manholes.

2.5.7 Length of Mains and Slope Measurement

Length of mains shall be measured horizontally, from the center of manhole structure to the center of the manhole structure, not the center of the manhole lid. Main slopes shall be calculated using the outside invert of the upstream manhole to the outside invert of the downstream manhole. These length and slope calculations shall be used for construction submittals as well as for the Drawings of Record submittal.

2.5.8 Manholes

Manholes shall be installed at the following locations:

- (a) The end of each main
- (b) All changes in grade, size, horizontal or vertical alignment

SECTION III – MATERIAL SPECIFICATIONS

- (c) Wastewater manholes shall be aligned and spaced so that the change of flow direction is not at an acute angle.
- (d) All intersections
- (e) Main distances not greater than four-hundred feet (400')
- (f) Manhole lids shall be located outside of the vehicle wheel path on all road installations

Manholes shall not be located in the following areas:

- (a) Within ten feet (10') of domestic water infrastructure
- (b) Where surface water can accumulate (i.e. drainage pans, ditches, floodplains, etc.)
- (c) Within a 100-year floodplain

The manhole access opening shall be a minimum of twenty-four inches (24") in diameter and any Wastewater Mains over eighteen inches (18") shall have thirty-six (36") diameter manhole access openings. The minimum manhole diameter size shall be based on the largest main penetrating the manhole and adhere to the following:

Table D-2: Manhole Sizing Criteria

Main Diameter	Minimum Manhole Diameter
8 to 18 inches	48-inch
21 to 27 inches	60-inch
30 inches and above	72-inch

Bar screen manholes may be required in new developments to prevent construction debris from entering the collection system. Bar screen manholes shall be required in steep slope applications. Refer to Detail D-03.

Inside Drop manholes shall not be permitted and outside drop manholes will be considered on a case-by-case basis. If a drop manhole is approved, it shall be provided for where a main enters a manhole twenty-four inches (24") or more above the manhole invert. Refer to Standard Detail D-02.

2.5.9 Manhole Clearances

Manholes must be exposed and accessible at all times. A minimum clearance of three (3) feet from the rim of the manhole to the face of any surface obstruction object must be met. The 3-foot minimum must be level. Manholes are not permitted to be in low spots or holes. If the required clearances are not met, ERWSD personnel will remove such obstructions after seven (7) days written notice is given or immediately in cases of

emergency, the costs for which may be added as a charge to the property owner's monthly bill.

2.5.10 Manhole Connections

Any new main connection eight inches (8") or greater within a manhole shall match the crown of pipe to crown of pipe at the highest existing main currently within the manhole.

2.5.11 Location/Marking Tape

All lines connected to District mains in any way shall be marked with the appropriate marking tape per Section 3.6 and shall be placed twenty-four inches (24") above the pipe.

2.5.12 Pipe Material

The District requires the same pipe material to be installed from manhole to manhole.

2.5.13 Lift Stations

Lift stations are specifically discouraged. In the event lift stations are approved by the District, they shall be considered Major Facilities and will be designed, constructed and financed by the District in accordance with Article IX.

2.5.14 Maintenance Access

All mains, whether in easements or right-of-way, shall allow for vehicular access to conduct maintenance activities. Access benches shall have a minimum width of twelve feet (12'), a centerline grade of no more than ten percent (10%), and a maximum cross slope of six percent (6%) per Detail D-06. Vehicular turnarounds shall be provided at all dead-end mains in conformance with Detail D-08.

2.6 Protection of Potable Water Supplies

When wastewater mains are proposed near any potable water supply facilities, the following requirements of the Colorado Department of Public Health and Environment's (CDPHE) Potable Water System Design Criteria Manual shall apply:

2.6.1 Cross Connections Prohibited

There shall be no physical connections between a public or private potable water supply system and a main or appurtenance thereto which would permit the passage of any wastewater or polluted water into the potable supply. No water pipe shall pass through or come into contact with any part of a Wastewater Main or manhole. There shall be no physical connections between a stormwater conveyance system and a main or appurtenance thereto which would permit the passage of any storm water into the

SECTION III – MATERIAL SPECIFICATIONS

wastewater collection system. No stormwater water pipe shall pass through or come into contact with any part of a Wastewater main or manhole.

2.6.2 Relation to Water Works Structures

Minimum distances from public water supply wells or other water supply sources and structures shall be provided.

2.6.3 Separation of Infrastructure

Parallel Installation of Mains, Services and Appurtenances

Wastewater pipes must be laid a minimum of ten feet (10) horizontally (edge to edge) from any existing or proposed potable infrastructure (i.e., Water Mains, Water Services, Water Appurtenances).

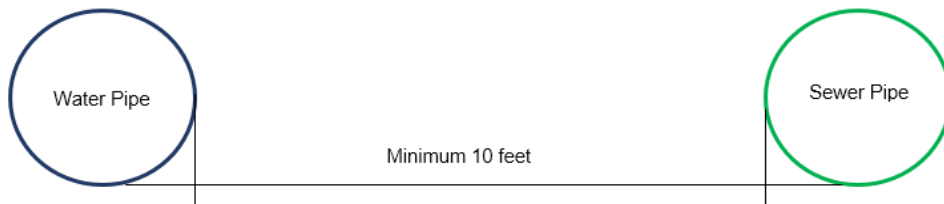

Parallel Horizontal Separation Exception

In cases where it is not practical to maintain a ten foot (10) separation, the District may allow the installation of the Wastewater pipe closer to a potable pipe given the following requirements are met. The potable pipe is on a separate trench or on an undisturbed earth shelf located on the “uphill” side of the Wastewater pipe and at an elevation, so the bottom of the potable pipe is at least eighteen inches (18) above the top of the Wastewater pipe. The Wastewater pipe must be pressure rated to 150 psi meeting AWWA standards and must pass a pressure test to ensure water tightness.

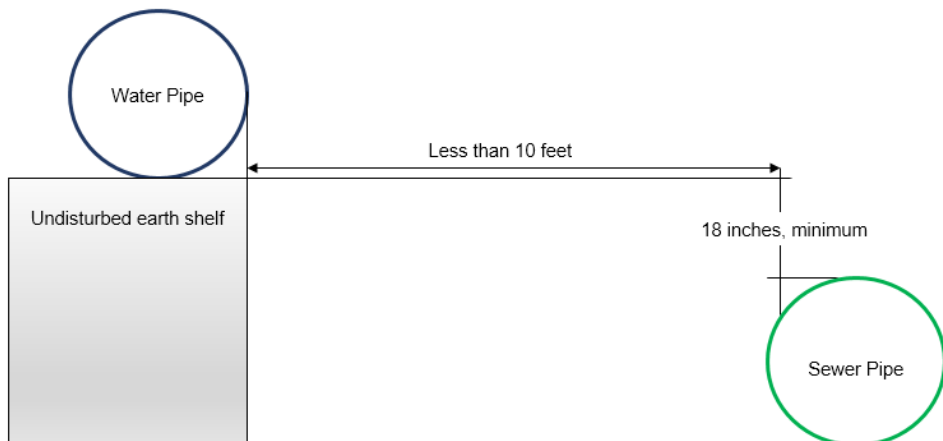

Crossings of Mains and Services

Wastewater pipes that cross, existing or proposed Water pipes, must be installed a minimum of eighteen inches (18) vertically outside edge to outside edge. At crossings, one full length of water pipe must be located so both joints will be as far from the Wastewater pipe as possible.

Vertical Separation Exception - Wastewater under Water

If the Wastewater pipe crosses a Water pipe, and there is less than eighteen inches (18) vertically between the outside edges of the pipes, the Wastewater pipe must be installed with secondary containment.

Acceptable options for secondary containment include a pipe casing extending no less than nine feet (9) each side of the crossing. The pipe casing must be a single section of steel, ductile iron, or polyvinylchloride (PVC) with casing pipe end seals and no joints. The design must include a means to support the interceptor or non-potable pipe to prevent settlement and permit maintenance of the water pipe without damage to either pipe. Alternatively, concrete or controlled low strength material (e.g., flowable fill) encasement of either pipe extending no less than ten feet (10) each side of the crossing may be used. **Crossings involving jointless pipe such as HDPE or copper do not require installation of secondary containment.**



SECTION III – MATERIAL SPECIFICATIONS

3.1 General Requirements

All materials must conform to these Material Specifications and shall be new and undamaged.

Acceptance of materials, or the waiving of inspection thereof, shall in no way relieve the Applicant of the responsibility for furnishing materials that meet the requirements of these Specifications.

3.2 Pipe and Fittings

The following materials are approved for District mains:

3.2.1 Polyvinyl Chloride (PVC) gravity pipe

Main installations from eight to fifteen inches (8" to 15") in diameter shall conform to ASTM D3034 and shall be either SDR-35/PS46 or SDR-26/PS115.

Main installations from eighteen to twenty-seven inches (18" to 27") in diameter shall conform to ASTM F679 and shall be SDR-26/P115. Push on joints and molded rubber gaskets shall conform to ASTM D3212.

Maximum pipe segment lengths shall be twenty feet (20'). Joint lubricant shall be non-toxic and water-soluble and supplied by the pipe manufacturer.

3.2.2 Polyvinyl Chloride (PVC) pressure pipe

(a) *Yelomine*

Yelomine pipe shall be SDR-21, restrained joint PVC pressure pipe and fittings having a minimum cell classification of 12454 as defined in ASTM D1784 and materials in conformance with ASTM D2241.

(b) *C-909*

AWWA C-909 Molecularly Oriented Polyvinyl Chloride (PVCO) pressure pipe may be used for 8 " through 12" diameter pipe, and shall be pressure class 235 psi, DR18, with push-on joints and flexible elastomeric seals ASTM D3139/ASTM F477. All spigot ends shall be beveled to manufacturer's specifications with gaskets meeting ASTM F477 and joints in compliance with ASTM D3139.

3.2.3 Ductile Iron Pipe (DIP)

Ductile Iron Pipe shall be per ASTM A746, Class 52, 350 psi, AWWAC151. Push-on joints shall be ANSI/AWWA C111/A21.11. Factory applied Protecto 401, or equivalent, ceramic epoxy interior lining for DIP & fittings. Manufactured by U.S. Pipe and Foundry Company/Griffin Pipe Products or approved equal.

3.2.4 Service Line Taps

Factory wyes shall be used for all service line connections with new main installations See Appendix B for requirements for new service line connections to existing mains.

3.2.5 Transition Adapter

If permitted on a case-by-case basis, Harco transition adapters or Shear Guard couplers may be used for pipe material transitions with prior approval. Fernco couplers shall not be permitted.

3.3 Manholes

3.3.1 Manhole

Manhole sections, base, riser, conical top sections, flat slab tops, and joint sealants between manhole sections shall be in accordance with ASTM C 478. Concrete used in cast in place-manhole bases shall be per Section 3.3.10. All cone sections shall be the eccentric type. Openings through manhole risers shall be cored or cast-in, and access opening shall be twenty-four-inch (24") diameter. Flat lid slabs are required on manholes with a depth of less than five feet (5') and must be eccentric.

3.3.2 Water Tightness

Manholes shall be watertight and constructed of precast concrete. Barrel sections, cones and frame joints shall all be sealed with a double Rub R Nek, or other equivalent material approved by the District. In areas of high groundwater or otherwise required by the District, a bituminous coating, or approved equal waterproofing material, shall be applied to the exterior of the manhole. Manhole vacuum testing shall be required by the District on all manholes in all areas of high groundwater.

3.3.3 Rings and Covers

Manhole rings and covers shall be heavy duty castings ASTM A 536 or gray cast iron per ASTM A 48 and all components shall be traffic rated to AASHTO HS-20. Ring and cover combined weight shall be greater than 245 pounds and machined to fit securely with a non-rocking cover. Manhole covers shall be twenty-four inch (24") in diameter and have a minimum of twenty-two and one-eighth inches (22-1/8") diameter clearance, have a waffle pattern with a flat lid and the lettering "SEWER" cast on the cover. Covers

shall be D & L brand model A-1043 or accepted equal. Precision Cover Systems, Inc. (PCSI) fully-adjustable manhole covers with variable grade rings shall be installed in roadways.

3.3.4 Grade Rings

Grade rings shall be in accordance with ASTM C 478 and the maximum height of grade rings shall not exceed eleven inches (11”).

3.3.5 Manhole steps

Steps shall be comprised of grade 60 deformed rebar encased in a polypropylene copolymer plastic with a tread width of fourteen inches (14”). The steps shall be M.A. Industries No. PS2-PF or PS2-PF-DF or approved equal. Steps shall be cast in place during manufacturing of the manhole sections and shall be six inches (6”) from face of manhole. The top most step shall be installed between eighteen (18”) and twenty-four inches (24”) from the rim of the manhole. Manhole steps shall be vertically aligned and plumb. Steps shall be typically spaced at twelve inches on-center vertically with a maximum spacing of sixteen inches (16”). Steps shall not be installed in the "chimney" portion of the manhole. Entry steps shall be located in the barrel and cone sections of the manhole. See Standard Manhole Detail D-01.

3.3.6 Joint Sealant

Joints shall be sealed with Rub-R-Nek LTM or approved equal installed on the inner and outer ring. Sealant shall be a flexible gasket-type of Butyl rubber, Federal Specifications SS-S-210 (210-A), per ASTM C990-09, AASHTO M-198 75 1. Sealant shall be applied on all surfaces between precast concrete adjusting ring and casting, individual precast concrete adjusting rings, and precast concrete adjusting ring and cone joints. A compatible primer or solvent as recommended by manufacturer of butyl base material shall be used to prepare surfaces prior to application of butyl base material and riser rings. Two gaskets with a minimum cross sectional area equivalent to one inch (1”) in diameter are required per joint on forty-eight inch (48”) diameter manholes. Gaskets for manholes greater than forty-eight inches (48”) in diameter shall have a minimum cross sectional area of one and one-half inches (1 ½”).

3.3.7 Pipe to Manhole Seal

KOR-N-Seal, A-Lok, or approved equal flexible rubber boot in a cored hole per ASTM C 923 shall be used for installations in pre-cast bases.

For installations in cast-in-place bases (upon approval and on existing mains only), all pipe-to-manhole connections shall use Kor-N-Seal, A-Lok or approved equal, water stops per ASTM C-923

3.3.8 Flow Channel

The flow channel straight through a manhole should be made to conform as closely as possible in shape and slope to that of the connecting mains and shall have two tenths of a foot (0.2') minimum fall through the channel for a standard manhole. Channel depth and width shall equal the largest pipe diameter. The channel walls should be formed or shaped to the full height of the crown of the outlet main in such a manner as to not obstruct maintenance, inspection or flow in the Wastewater Mains.

3.3.9 Bench

All manholes shall be constructed with a full bench configuration, in which the top of the invert channel walls shall match the crown of pipe elevation. The horizontal bench surface shall be sloped at a minimum of one-half inch ($\frac{1}{2}$ ") per foot, maximum of one inch (1") per foot with a medium broomed finish, perpendicular to the main direction of flow.

3.3.10 Manhole Base

The foundation for each manhole base shall be prepared by replacing unsuitable material with sub grade stabilization material in accordance with Appendix E-Earthwork.

The manhole base shall be precast (in accordance with ASTM C478) unless the manhole ties into an existing main, in which case a cast-in-place base may be used. The invert shall be formed and smoothly finished to match the shape and elevation of all pipes connected to the manhole. Where the Wastewater pipe is designed with a continuous grade through the manhole, the pipe shall be laid through the manhole location, the top half of the pipe cut out and the manhole base formed around the bottom half of the pipe.

All concrete used in construction of cast-in-place manholes and bases shall be CDOT Class D. Concrete reinforcement shall be epoxy-coated steel reinforcing bars in accordance with ASTM A-615, Grade 60. In instances where a manhole ties into an existing main and a cast-in-place base is used, the first pre-cast manhole section shall be placed on the concrete base structure before the base has taken initial set, or the section shall be grouted into a suitable groove formed in the top of the manhole base. The first section shall be adjusted to the proper grade and alignment so that it is uniformly supported by the base concrete and not bearing on any of the pipes. The manhole steps shall be located one foot left or right of the main inflow pipe.

The remaining pre-cast sections shall be placed and aligned to provide vertical sides and alignment of the ladder rungs. Plumbness shall be checked as each barrel section is added. A bitumastic or other approved sealer shall be placed between pre-cast

sections so that the completed manhole is rigid and watertight. The sealer shall be placed both on the inside lip as well as the outside lip of each section.

3.3.11 Interior Coatings

For drop manholes (or other applications as identified by the District), manhole interiors shall be coated with a Polyamidoamine Epoxy Primer with Polyamidoamine Epoxy Top Coat such as Tnemec Epoxoline Series L69 or equivalent. Preparation and application shall be per manufacturers' recommendations and installed by a qualified applicator. All manhole coatings are subject to inspection by a 3rd party coatings inspector.

3.4 Concrete/Grout

3.4.1 General Requirements

Contractor shall provide the District Inspector with a specification sheet or mix design from the concrete supplier.

3.4.2 Concrete

All concrete used in construction of cast-in-place manholes and bases shall be CDOT Class D. Construction shall be in conformance with the Detail D-01.

3.4.3 Mortar and Grout

Non-shrink mortar and grout used in the shaping of inverts, grade ring gaps, sealing penetrations, or setting and anchoring cast iron shall consist of one part Type II Portland Cement and two parts of fine, clean sand. Only sufficient water shall be added to provide a stiff, workable cement mixture for proper troweling. Hydrate lime or masonry cement shall not be used. Where relatively thin portions of grout are to be applied (to a flow channel or top of bench) an approved epoxy bonding coat shall be applied to the exposed concrete surfaces prior to grouting.

3.5 Locating Disk

The District will provide green 3M brand Full-Range Disk Marker locating disks to the contractor for stub outs. The contractor shall ensure their correct installation.

3.6 Marking Tape

The installation of green marking tape is required on all Wastewater Mains and service lines. The tape shall be installed approximately 24 inches (24") above the main or line. The tape shall meet the following specifications:

- (a) Five (5)-mil thick Polyethylene material.
- (b) Solid green color with black lettering.

(c) Six inches (6") in width.

3.7 Casing Material and Spacers

Carrier pipes to be installed inside casings shall be installed with self-restraining casing spacers. Casing spacers shall provide axial thrust restraint to prevent pipe joint deflection during and after installation. They shall also provide dielectric insulation between the carrier pipe and the casing and facilitate installation of the carrier pipe into the casing. See Sewer Main Casing Detail D-5. Pipe casing shall be smooth wall welded steel ASTM A-53 Grade B cylinder fabricated in accordance with AWWA C200. External loading shall be AASHTO HS-20 highway or E-80 railroad loading, railroad loading plus jacking load. Casing joints shall have ends beveled for field welding, be butt welded with complete joint penetration welds around the entire circumference of the pipe, and be formed and accurately manufactured so that when pipes are placed together and welded, they form a continuous casing with a smooth and uniform interior surface. Interlocking joints shall be Permalok Interlocking Pipe Joining System. Casing spacers shall be stainless-steel, two-piece bolt-on style, minimum fourteen (14) gauge thickness and a minimum length of eleven inch (11"); casing spacers shall be installed every six feet (6') of the pipeline to support the pipe barrel and the weight of its contents, or at an appropriate spacing as determined by the engineer. The four runners shall be eleven inches (11") long at a minimum and manufactured of high abrasion resistant, low coefficient of friction, glass filled polymer. Runner heights shall be set to center the carrier pipe in the casing. Risers shall be ten (10) gauge maximum, and the coating shall be fusion-bonded epoxy or heat fused PVC. Casing spacer models shall be Uni-Flange Series UFRCS1300, Advance Products and Systems, Inc. SI-12; Pipeline Seal and Insulator, Inc. C12G or approved equivalent. Restrained casing spacers shall be provided at all pipe joints. Restrained casing spacers shall be Uni-Flange Series UFRCS1390 P or approved equivalent.

Casing end seals shall be preformed and designed to prevent entry of water or loss of material from casing. The end seals shall be made of one-eighth inch (1/8") thick 60 durometer EPDM or neoprene rubber held together with mastic strips to seal the edges. The seals shall overlap the casing pipe by two inches (2") and shall be held on with AISI 304L stainless steel worm gear clamps. Casing end seals shall be Advance Products and Systems, Inc. AC or AW; Pipeline Seal and Insulator, Inc. C or W; or approved equivalent.

3.8 Tracer Wire (REQUIRED)

See Appendix E

SECTION IV – PIPE INSTALLATION & CONSTRUCTION

4.1 Safety

Job site safety shall be the responsibility of the contractor. The District Inspector may refuse to enter a jobsite if deemed unsafe by Occupational Health and Safety Act (OSHA) standards. Failure to provide a safe jobsite may prevent the District from conducting an inspection.

4.2 Handling of Materials

Pipe and fittings shall be loaded and unloaded by lifting so as to avoid shock or damage. Under no circumstances shall material be dropped. If, however, any part of the pipe is damaged, the replacement or repair of the damaged pipe shall be done to the satisfaction of the District. Any pipe or fittings that are not acceptable to the District shall be removed from the job site immediately. All pipe-handling equipment and pipe handling methods shall be in accordance with the methods and equipment recommended by the manufacturer.

Under NO circumstance shall forks be inserted into any pipe and or fitting. Pipe shall be stored and handled in accordance with manufacturer's recommendations. Any pipe with UV degradation or bowing may be rejected by the District Inspector. All pipe shall be delivered to the project site and stored with factory applied end caps intact.

4.3 Inspection and Preparation of Pipe and Fittings

Before placing pipe in the trench, each pipe or fitting shall be thoroughly cleaned of all foreign material, kept clean at all times thereafter, and carefully examined for cracks, warping, or any other defects before installation. Bell ends and spigot ends are to be examined and free of defects. Following the inspection, end caps shall be replaced prior to placing the pipe in the trench.

All lumps, blisters and excess coatings shall be removed from the pipe and fitting, and the outside of the spigot and the inside of the bell shall be wiped clean, dry and free from oil and grease before the pipe or fitting is installed. Dirt and any other material must be removed from the barrel of the pipe before installation.

4.4 Cutting and Fitting of Pipe

Pipe shall be cut in accordance with manufacturer's recommendations, whenever necessary, to conform to location of fittings, line, or grade. All cuts, when required, shall be straight, true and beveled and may be made with plastic pipe cutters or completed per the DIPRA Guidelines for Field Welding and Cutting Ductile Iron Pipe (August 2015).

SECTION IV – PIPE INSTALLATION AND CONSTRUCTION

All burrs shall be removed from the ends of cut pipe and the ends of the pipe lightly rasped or filed.

4.5 Pipe Alignment and Grade

Manholes shall be installed at staked locations and elevations. Main installation stakes for alignment and grade shall be set by a surveyor under the guidance of a Professional Land Surveyor who is registered in the State of Colorado.

Pipe shall be installed at a constant grade from manhole to manhole. No grade breaks or low spots will be accepted. Pipe shall be installed with the bell ends facing in the direction of installation, unless directed otherwise by the District. Where pipe is to be installed on a grade of ten percent (10%) or greater, the installation shall start at the bottom and shall proceed upward with the bell ends of the pipe up grade.

4.6 Temporary Plugs

A mechanical pipe plug shall be used as a temporary plug during line installation to isolate the mainline extension from the existing collection system. All temporary plugs shall be provided by the Contractor.

4.7 Frost

No pipe or appurtenant structure shall be installed upon a foundation into which frost has penetrated, or if at any time there is danger of ice formation. No pipe or appurtenant structure shall be installed unless backfilling can be completed before the formation of ice and frost.

4.8 Lowering of Material into the Trench

Proper implements, tools and facilities satisfactory to the District shall be provided and used by the Contractor for the safe and convenient performance of the work. All pipe, manholes, and accessories shall be carefully lowered into the trench piece by piece by means of suitable tools and equipment, in such a manner as to prevent damage to the materials. Under no circumstances shall the materials be dropped or dumped into the trench.

If damage occurs to any pipe, manholes or main accessories in handling, the District inspector may reject the damaged material at the discretion of the inspector.

4.9 Installation of Pipe

4.9.1 General Requirements

Factory applied end caps shall remain installed on the pipe while it is being placed in the trench to prevent foreign material from entering the pipe. The end cap shall be left in place until the connection is to be made to the adjacent pipe. During installation, no debris, tools, clothing or other foreign materials shall be placed in the pipe.

As each length of pipe is placed in the trench, the spigot end shall be centered in the bell and the pipe inserted to the manufacturer's recommended depth with a slow steady pressure without jerky or jolting movements and brought to correct line and grade. The pipe shall be secured in place with bedding material tamped under it, except at the bells. Precautions shall be taken to prevent dirt from entering the joint space. No wooden blocking shall be left at any point under the pipeline. All pipe joints shall be uniform and smooth transitions shall exist from joint to joint or fitting. See Appendix E for bedding, backfill and compaction requirements.

4.9.2 Ductile Iron Pipe

Push-On Joints: The inside of the bell, the outside of the spigot end, and the rubber gasket shall be thoroughly cleaned to remove oil, grit, excess coating, and other foreign matter. The rubber gasket shall be flexed inward and inserted into the gasket recess of the bell socket. NSF-61 approved gasket lubricant per the manufacturers recommendations shall be applied to either the inside face of the gasket, and the spigot end of the pipe, per the manufacturer's recommendations.

The spigot end of the pipe shall be placed in the bell end with care to prevent the joint from contacting the ground. Pipe furnished without a depth mark on the spigot end shall be marked before assembly to ensure insertion to the manufacturer's recommended depth. The pipe shall be kept in straight alignment and the joint shall be completed by inserting the pipe to the manufacturer's recommended depth with a slow, steady pressure by using a long pry bar, jack, lever puller, or backhoe bucket. A timber header should be used between the pipe and the jack or backhoe bucket to avoid damage to the pipe.

Upon completion of joining push-on joint pipe, an inspection shall be made to ensure that the gasket is correctly aligned in the gasket recess of the bell socket and not twisted or turned.

4.9.3 Polyvinyl Chloride Pipe

Elastomeric Gasket Joints: Immediately before joining two (2) lengths of PVC pipe, the inside of the bell or coupling, the outside of the spigot and the elastomeric gasket shall be thoroughly cleaned to remove all foreign material.

Lubrication of the joint and rubber gasket shall be done in accordance with the pipe manufacturer's specifications.

Care shall be taken that the correct elastomeric gasket, compatible with the annular groove of the bell, is used. Insertion of the elastomeric gasket in the annular groove of the bell or coupling must be in accordance with the manufacturer's recommendations.

The spigot and bell or coupling shall be aligned and inserted to the manufacturer's recommended depth or reference line. Installation or pushing shall be done in a smooth, steady motion. Upon completion of joining the pipe, an inspection shall be made to assure that the gasket is correctly aligned in the gasket recess of the bell socket and not twisted or turned. NO deflection will be allowed at a joint of PVC pipe.

4.9.4 Yelomine Pipe

Installation of Yelomine pipe shall be in accordance with the manufacturer's recommendations and specifications. Cleanout caps shall be installed with non-permanent gaskets where applicable.

4.9.5 Job-Mixed Concrete

Job-mixed concrete shall be thoroughly mixed to combine aggregates, cement, and water into a uniform mass.

4.9.6 Ready-Mixed Concrete

Said materials must be proportioned, mixed and transported in accordance with ASTM C94. Any concrete not plastic and workable when it reaches project shall be rejected. See Section 3.4 for material specifications.

4.10 Manholes

Manholes shall be precast, watertight and constructed in accordance with the District's standard details and per Section 3.3. For precast manhole bases, the area underneath the manhole base shall be excavated and bedding material shall be placed and compacted to the required elevation. The manhole base shall then be lowered into the trench and checked for proper bearing on the subgrade, proper elevation and orientation to receive the incoming and outgoing wastewater at the designated invert elevation. If the invert elevation varies by more than plus or minus one half inch (1/2")

SECTION IV – PIPE INSTALLATION AND CONSTRUCTION

from the designated invert elevation, the base shall be removed and reset. The concrete invert channel and bench shall be constructed following the connection of all wastewater pipes to the manhole. The flow channel shall be smooth and true to the wastewater pipe invert elevations, with uniform cross section and slope, either straight or with a continuous curve between inlet and outlet of pipes. To eliminate free fall conditions in a manhole resulting from invert elevation differentials between incoming and outgoing pipes, the Contractor shall form and construct suitable channels in the bottom of the manhole connecting the inverts. Shape channel base and bench per Sections 3.3.8 and 3.3.9, respectively. New manholes shall have pre-formed holes for pipe installation and existing manholes shall be cored to install pipe and connector. Chip existing concrete bench inside manhole and shape smooth continuous invert for connections to existing manholes. All pipe-to-manhole connections and grade adjustment rings shall be sealed and grouted with non-shrink materials and be watertight. All lift holes shall be filled with non-shrink grout.

All dimensions, locations and elevations shall be coordinated by the Applicant and Contractor and meet the requirements of the District. Cast-in-place manhole bases will only be allowed when connecting to an existing main.

4.11 Service Lines

Refer to Appendix B, Section II.

SECTION V – TESTING AND ACCEPTANCE

5.1 General Requirements for Connections

Connections to the District system shall be inspected and approved by the District prior to backfilling.

5.1.1 Service Connections

Refer to Appendix B.

5.1.2 Connections to Manholes

All connections shall match the crown of pipe to crown of pipe at the highest existing main or per the direction of the District. All new main installations shall require reformed benches that meet all District standards.

5.2 Testing – Wastewater Mains

5.2.1 Alignment

Straight alignment shall be checked by using either a laser beam or lamping.

5.2.2 Low Pressure Air Testing – General Requirements

The air test shall, as a minimum, conform to the test procedure described in ASTM F 1417 Standard Practice for Installation Acceptance of Plastic Non-Pressure Wastewater Lines Using Low-Pressure Air. Deflection testing should occur prior to air test.

5.2.3 Low Pressure Air Testing Procedure

- (a) Lines must be cleaned by flushing or by other means before the low-pressure air test is to begin.
- (b) Isolate the wastewater line to be tested and ensure that all other outlets from which air could escape are properly sealed. In this step of the procedure, it is necessary to inspect the manhole invert being plugged to be sure that it has no damage which will be covered by the plug and not detected with the low-pressure air test.
- (c) Determine the duration of the test by using the accompanying tables at the end of this section.
- (d) Begin the test by connecting the air source to the inlet tap. Slowly add air until the internal pressure of the test section reaches a pressure 4.0 psig. If ground water back pressure exists, it must be quantified by the Engineer prior to testing.

SECTION V – TESTING AND ACCEPTANCE

- (e) After the constant pressure of 4.0 psig is obtained, regulate the air supply so that the pressure is maintained between 3.5 to 4.0 psig for at least 2 min. Depending on air/ground temperature conditions, the internal air temperature will stabilize in equilibrium with the temperature of the pipe walls. The pressure will normally drop slightly until equilibrium is obtained; however, a minimum of 3.5 psig is required.
- (f) Once the pressure has stabilized to 4.0 psig (plus the average ground water back pressure, if applicable) disconnect the air supply from the control panel. Observe the continuous monitoring gauge and decrease the internal pressure to no less than 3.5 psig. At a reading of 3.5 psig or within the range of 3.5 to 4.0 psig, stop decreasing the pressure and commence timing with a stopwatch or watch with a second hand or digital readout in minutes and seconds with an accuracy of 0.1.s.
- (g) Once the predetermined time period from the formula or table above has elapsed, observe the continuous monitoring gauge to obtain the amount of pressure lost during the test duration. If the pressure drop is found to be less than 1.0 psig (or 0.5 psig in circumstances where a shorter test duration is desired), the section is presumed to be free of any leaks or defective joints. If the pressure drop is 1.0 psig or greater (0.5 psig or greater in circumstances where a shorter test duration is desired), the test section has failed due to excessive pressure loss. When low-pressure air testing of a wastewater line results in a failure the Contractor, at his/her own expense, shall detect the leak or defect and repair or replace whatever is necessary to remedy such defect in a manner acceptable to the Owner.

TABLE D-3: Minimum Time for a 1.0 psig Pressure Drop for Size and Length of Pipe for Q = 0.0015

Pipe Diameter, in.	Minimum Time, min: s	Length for Minimum Time, ft	Time for Longer Length, s	Specification Time for Length (L) Shown, min:s								
				100 ft	150 ft	200 ft	250 ft	300 ft	350 ft	400 ft	450 ft	
4	3:46	597	0.380 L	3:46	3:46	3:46	3:46	3:46	3:46	3:46	3:46	3:46
6	5:40	398	0.854 L	5:40	5:40	5:40	5:40	5:40	5:40	5:40	5:42	6:24
8	7:34	298	1.520 L	7:34	7:34	7:34	7:34	7:36	8:52	10:08	11:24	
10	9:26	239	2.374 L	9:26	9:26	9:26	9:53	11:52	13:51	15:49	17:48	
12	11:20	199	3.418 L	11:20	11:20	11:24	14:15	17:05	19:56	22:47	25:38	
15	14:10	159	5.342 L	14:10	14:10	17:48	22:15	26:42	31:09	35:36	40:04	
18	17:00	133	7.692 L	17:00	19:13	25:38	32:03	38:27	44:52	51:16	57:41	
21	19:50	114	10.470 L	19:50	26:10	34:54	43:37	52:21	61:00	69:48	78:31	
24	22:40	99	13.674 L	22:47	34:11	45:34	56:58	68:22	79:46	91:10	102:33	
27	25:30	88	17.306 L	28:51	43:16	57:41	72:07	86:32	100:57	115:22	129:48	
30	28:20	80	21.366 L	35:37	53:25	71:13	89:02	106:50	124:38	142:26	160:15	

NOTE 1—See Practice UNI-B-6.

NOTE 2—Consult with pipe and appurtenance manufacturer for maximum test pressure for pipe size greater than 30 in. in diameter.

SECTION V – TESTING AND ACCEPTANCE

Table D-4: Minimum Time for a 0.5 psig Pressure Drop for Size and Length of Pipe for Q = 0.0015

Pipe Diameter, in.	Minimum Time, min:s	Length for Minimum Time, ft	Time for Longer Length, s	Specification Time for Length (L) Shown, min:s							
				100 ft	150 ft	200 ft	250 ft	300 ft	350 ft	400 ft	450 ft
4	1:53	597	0.190 L	1:53	1:53	1:53	1:53	1:53	1:53	1:53	1:53
6	2:50	398	0.427 L	2:50	2:50	2:50	2:50	2:50	2:50	2:51	3:12
8	3:47	298	0.760 L	3:47	3:47	3:47	3:47	3:48	4:26	5:04	5:42
10	4:43	239	1.187 L	4:43	4:43	4:43	4:57	5:56	6:55	7:54	8:54
12	5:40	199	1.709 L	5:40	5:40	5:42	7:08	8:33	9:58	11:24	12:50
15	7:05	159	2.671 L	7:05	7:05	8:54	11:08	13:21	15:35	17:48	20:02
18	8:30	133	3.846 L	8:30	9:37	12:49	16:01	19:14	22:26	25:38	28:51
21	9:55	114	5.235 L	9:55	13:05	17:27	21:49	26:11	30:32	34:54	39:16
24	11:20	99	6.837 L	11:24	17:57	22:48	28:30	34:11	39:53	45:35	51:17
27	12:45	88	8.653 L	14:25	21:38	28:51	36:04	43:16	50:30	57:42	64:54
30	14:10	80	10.683 L	17:48	26:43	35:37	44:31	53:25	62:19	71:13	80:07

NOTE 1—Consult with pipe and appurtenance manufacturer for maximum test pressure for pipe size greater than 30 in. in diameter.

5.3 Manhole Testing – General Requirements

Manhole vacuum testing shall be required by the District on all manholes via the vacuum test per ASTM C1244, “Standard Test Method for Concrete Sewer Manholes by the Negative Air Pressure (Vacuum)” prior to backfill.

5.3.1 Manhole Testing Procedure

- (a) Plug all inlets and outlets.
- (b) Install the vacuum tester head assembly on the manhole.
- (c) Attach the vacuum pump assembly to the proper connection on the test head assembly. Make sure the vacuum inlet/outlet valve is in the closed position.
- (d) Inflate the sealing element to twice the test pressure to be used. Do not over inflate.
- (e) Start the vacuum pump assembly engine and allow preset RPMs to stabilize.
- (f) Open the inlet/outlet ball valve and evacuate the manhole to ten-inch (10") Hg (mercury) that is equivalent to approximately 5 PSIG (0.3 bar) backpressure.
- (g) Close the vacuum inlet/outlet ball valve, disconnect the vacuum pump and monitor the vacuum for one (1) minute.
- (h) Allowable leakage - less than one-inch (1") Mercury (Hg) in one (1) minute.
- (i) All manholes that do not meet the minimum amount for the leakage rests must be repaired and re-tested.

5.4 Television Inspection – General Requirements

Prior to construction/final acceptance of any wastewater line by the District, the main shall be inspected internally by television as outlined in this Section. Leakage testing shall be performed prior to televising. The complete job is ready for television inspection when the following work has been completed.

- (a) All wastewater pipes are installed and backfilled.
- (b) All attributes are in place, all inverts are complete and pipelines are accessible.
- (c) All other underground facilities, utility piping and conduits are installed.
- (d) Pipelines have been jet cleaned.
- (e) Final air test has been completed.

When the above work is complete, the Contractor shall arrange for the television inspection. The Contractor of the project will notify the District in writing as to the scheduled date of the television inspection.

After conditions a through e as outlined above, are met, the entire job will be televised.

- (a) A video, accompanied by Standard Form 6.3 shall document defects requiring correction.
- (b) If no deficiencies are observed, the work will be considered satisfactory.

There is no acceptance tolerance for defects such as high and low spots (sags), joint separations, offset joints, chipped ends, cracked or damaged pipe, dimples or bumps in the pipe, or groundwater infiltration.

5.4.1 Inspection Format

Wastewater lines shall be inspected by means of remote CCTV. All CCTV work shall conform to current NASSCO-PACP standards. Contractor shall provide the District with CCTV inspections (video and data collected) entirely in electronic format. Mains shall be tested with three and a half (3.5) gallons of water per minute flowing during televising and shall follow the direction of flow. The camera must be centered in the pipe and the speed of travel shall be slow enough to inspect each pipe joint, and tee connection, and should not, at any time, be faster than 30 feet per minute. The documentation of the work shall consist of PACP CCTV Reports, PACP database, logs, electronic reports, etc. noting important features encountered during the inspection. All CCTV video observations shall be identified by audio and recorded on the District Standard Form D3 and is required to accompany each submittal.

5.4.2 CCTV Video Content

Submitted CCTV videos shall include:

- (a) Footage indicator
- (b) Running time
- (c) Date
- (d) Location
- (e) Beginning (upstream) and ending (downstream) manhole numbers for each run. Manhole numbers corresponding with the District's GIS mapping system shall be obtained by the District field inspector.

5.4.3 District Review

The Contractor will be notified in writing of any deficiencies revealed by the television inspection that require repair. If corrective work is indicated and the Contractor wishes to view CCTV videos, he shall contact the District to set a time for the viewing.

5.4.4 Correction of Deficiencies

Those segments of the pipeline system that have been corrected must be re-televised. The procedure outlined above will be repeated until all deficiencies observed by television inspection have been corrected to the complete satisfaction of the District. Prior to submittal to the District, the CCTV videos shall be reviewed by the Engineer, Applicant, and Contractor for any defect that may be visible. If CCTV videos and cut sheets are submitted to the District that are deemed "unacceptable," the Contractor shall be charged for the time taken by District personnel to review the CCTV videos. The minimum charge shall be one hundred dollars (\$100).

5.5 Wastewater Main Repairs

All proposed repairs must be approved by the District Inspector prior to actual repair. Once repair has been made, inspection will be required by a District Inspector. There will be no exception to this requirement. If a repair and/or correction is made in a wastewater line segment, the entire line segment shall be required to be re-televised with water flowing. A line segment is defined as the entire length of wastewater line from manhole to manhole.

5.6 Protection of Existing Wastewater System

On the outlet of the connection point to the existing District Wastewater Main, a mechanical plug shall be installed to prevent any flow, debris and or material from the newly constructed main line from entering the District's system. The plug shall be normally set on the downstream outlet of the manhole. Plugs shall be installed per the direction of the District's Inspector. The plug shall be a mechanical-type device and is to

be secured to the existing manhole to prevent loss of plug. The plug shall not be removed until Construction Acceptance has occurred.

The Contractor shall be required to make routine inspections of the mechanical plug to ensure that no leaking is occurring. If a leak is found, the Contractor shall immediately notify the District and take corrective action.

The District may perform a video inspection of existing Wastewater Mains that could potentially be impacted by construction activities prior to the start of construction and \ after the completion of construction. Any damage to existing facilities caused by the Contractor shall be repaired at the Contractor's expense.

5.7 Manhole Abandonment

Manholes to be abandoned in place shall have all pipes entering or exiting the structure plugged with lean concrete or controlled low strength material backfill (Flo-Fill) or a CIPP plug. For manholes with existing pipes too large to plug with fill, a bulkhead shall be constructed on the inside of the manhole to prevent the fill from entering the pipes. Manhole tops or cone section shall be removed to the top of the full barrel diameter section or to a point not less than twenty four (24) inches below final grade. The structure shall then be backfilled with lean concrete, Flo-Fill, screened rock, sand or other uniformly graded material. Surface restoration shall be completed to match the surrounding areas.

5.8 Wastewater Main Abandonment

When abandoning a Wastewater Main completely there must be watertight plugs installed on both ends of the Wastewater Main.

5.8.1 Wastewater Main With Manhole Connection Abandonment

When abandoning a Wastewater Main that is connected to a manhole a watertight plug shall installed on the end of the main not within the manhole and a CIPP plug shall be installed on the inlet within the manhole. When an inlet is abandoned the manhole channel must be re-benched.

SECTION VI – STANDARD FORMS AND DETAILS

Form D1: Pre-Construction Meeting Checklist for Sewer Main Installation

Form D2: Sewer System Acceptance Procedure

Form D3: Sewer Pipe Cleaning and Televising Cut Sheet

Form D4: Bill of Sale – Sewer Main

Form D5: Sewer Easement

Form D6: Lender’s Consent

Example Specification D1: Wastewater Flow Management Plan

Example Specification D2: Discharge Emergency Response Plan

D-01: Standard Manhole

D-02: Drop Manhole

D-03: Bar Screen Manhole

D-04: Anchor Manhole

D-05: Casing Detail

D-06: Sewer Maintenance Access

D-07: Groundwater Barrier

D-08: Arm Design Turnaround

D-09: Easement Width Detail

D-10: Sewer Pipe Insulation Detail

D-11: Water and Wastewater Separation

D-12: Dead End Manhole



Form D1: Pre-Construction Meeting Checklist for Sewer Main Installation

Project: _____ **Location:** _____

Date: _____ **Wastewater Plant:** _____

Attendees: _____

1. Customer Notification

2. All licenses and permits are secured for work.

3. A bill of materials has been provided and reviewed.

4. Site Safety

✓ OSHA safety standards and practices apply.

5. Survey

✓ Survey layout is complete and surveyor retained for as-built locations.

6. Temporary Plugs

✓ A mechanical pipe plug must be installed where new mains are connected to existing mains. This plug will remain until the district inspector approves removal

7. Installation of Pipe

- ✓ Factory applied end caps will remain on the pipe until connection is made
- ✓ Check all pipes for warping. Any pipe considered to be warped will be rejected.
- ✓ No "low" areas, pipe defects, dents, cracks or wide joints will be allowed.
- ✓ All mains and services in proximity to potable water infrastructure will meet district regulations pertaining to separation of services.

8. Minimum Depth of Bury and Bedding

- ✓ Four-feet six inches (4'-6")
- ✓ In cases where minimum bury depth cannot be achieved, one inch (1") of approved insulation will be required per foot of missing cover, minimum 2 inches.
- ✓ Six inches (6") of approved bedding material under the pipe and twelve inches (12") over the top of pipe.

9. Cutting of Pipe

- ✓ All cuts will be straight, true and beveled. All burrs will be removed from the ends of cut pipe and the ends lightly rasped or filed.

8. Tracer Wire and Joint Bonding

- ✓ Tracer wire *#12 AWG 0.1019" diameter copper conductor or copper clad steel insulated with a 30 mil, high-density, high molecular weight polyethylene (HDPE) insulation, green in color, and rated for direct burial use at 30 volts. Tracer wire will be installed on all sewer mains and service lines.
- ✓ The Applicant shall submit plans for a complete tracer wire system..
- ✓ All new mainline trace wire installations shall be located by the applicant using typical low frequency (512Hz) line tracing equipment, witnessed by the inspector, contractor, engineer and facility owner as applicable, prior to acceptance of ownership.
- ✓ Tracer wire grounding anode at all dead ends
- ✓ Tracer wire splicing/connections shall include two- and 3-way lockable connectors or a three way lug connector specifically manufactured for use in underground trace wire installation
- ✓ A No. 4 conductor and cad-welds or continuity straps will be used to bond each joint and fitting.

10. Manholes

- ✓ All manhole sections to be pre-cast except for tie-ins to existing segments.
- ✓ All manhole sections must be centered and have Rub-R-Neck gaskets on both inner and outer rings.
- ✓ All manhole inverts must be grouted to meet pipe (no standing water), all benches and flow channels must be formed and clean.

11. Marking Tape and Locating Disk

- ✓ Marking tape will be placed twenty-four inches (24") above the pipe for all main and service lines. Marking tape shall be solid green color with black lettering six inches (6") wide and of five (5)-mil thick PVC material.
- ✓ A 3M disk marker will be placed at all service ends with a maximum four foot (4') bury from finish grade

12. Testing

- ✓ All mains will be air tested.
- ✓ High groundwater manholes will be vacuum tested.
- ✓ All mains will be cleaned and televised, original videos and cut sheets will be submitted to the District in the required format. All videos must be reviewed for deficiencies by the owner/contractor/engineer prior to submittal to the District. Additionally, all corrective action taken by the owner/contractor/engineer will be completed, inspected by the District, and re-televised prior to initial submittal to the District.

13. Stub Outs

- ✓ Stub outs will be only allowed to the edge of easement or the property line.

14. Design Changes

- ✓ Engineer must submit any design changes to Construction Review for approval prior to implementation. Minor field changes may be approved by the District inspector and captured in As-Built documentation.

15. Construction acceptance includes the following:

- ✓ Rough grade inspection
- ✓ Manhole inspection
- ✓ Air testing, cleaning, televising completed and approved.
- ✓ Drawings of record submitted and approved.
- ✓ Easement documentation.
- ✓ Project costs.
- ✓ Bill of sale.

16. Warranty Period

- ✓ Will not start until Drawings of Record, Recorded Easement Documents, Project Costs Documents and Bill of Sale are received and approved by the District

Reference: Eagle River Water and Sanitation District Rules and Regulations Appendix D – Standard Specifications for Sewer Mains

Contractor: _____ **Engineer:** _____

Owner: _____ **Inspector:** _____



Form D2: SEWER SYSTEM ACCEPTANCE PROCEDURE

Location: _____
Project: _____ **Stations:** _____
Engineer: _____ **Applicant:** _____
Contractor: _____ **Excavator:** _____

CONSTRUCTION REVIEW TEAM (CRT)

Plans Approved for Construction:	Date	Approved By
_____	_____	_____

FIELD OPERATIONS INSPECTOR

Inspection/ Test Type	Date	Values	Sign Off
1) Sewer Assets Installed:	_____	_____	_____
2) Manhole(s):	_____	_____	_____
3) Main(s) Jetted/Cleaned:	_____	_____	_____
4) Main(s) Televised:	_____	_____	_____
5) Low PSI Air Test:	_____	_____	_____
2) Tracer Wire Testing	_____	_____	_____
6) Rough Grade:	_____	_____	_____
7) As-Built/ GIS Review:	_____	_____	_____
8) Final Grade and Paving:	_____	_____	_____

DEVELOPMENT REVIEW COORDINATOR

11) Construction Acceptance	Date	Sign Off
_____	_____	_____

FIELD OPERATIONS INSPECTOR

	Date		Sign Off
12) 2-Year Warranty WO Created	_____	_____	_____
13) 2-Year Warranty Inspection	_____	_____	_____

DEVELOPMENT REVIEW COORDINATOR

14) Final Acceptance	_____	_____
-----------------------------	-------	-------



Form D3: SEWER PIPE CLEANING & TELEVISIONING CUT SHEET

----ALL APPLICABLE INFORMATION MUST BE COMPLETED----

Project: _____ Map Page: _____

Street: _____ District/ City: _____

Owner: _____ Contractor: _____

Date Flushed: _____ Date Televised: _____ Tape No.: _____

TV Company: _____ TV Operator: _____

Pipe Type: _____ Pipe Diameter: _____ Pipe Slope: _____

Joint Length: _____ Length of Run: _____ Surface Cover: _____

Dist. Top of Cone to Rim: _____ MH Lid Diameter: _____ MH Condition: _____

Camera Travel: _____ MH Infiltration: YES _____ NO _____

With Flow: _____ GPM: _____

Against Flow: _____

Upstream MH #: _____ Downstream MH #: _____

Is the Pipe Condition Adequate? _____

Will the pipe need to be repaired? _____

Does the Pipe need to be repaired ASAP? _____

----Contractor to fill out cut sheet on following page----

Form D3: Sewer Pipe Cleaning & Televising Cut Sheet

Distance to: (FT)	Service Size/ Type	Service Clock Position	Lot # Street #	Additional Remarks (Please indicate lengths of cracks, low areas, problem areas, etc.)

General Comments: _____

BILL OF SALE – SEWER MAIN

KNOW ALL MEN BY THESE PRESENTS, that _____, (“Seller”), for and in consideration of the mutual promises and assurances made herein, the sufficiency of which is hereby acknowledged, and other valuable consideration to be paid by **Eagle River Water and Sanitation District** (“District”), a quasi-municipal corporation of the State of Colorado has bargained and sold, and by these presents does grant and convey unto the District, its successors and assigns, the following property:

The sewer system, equipment, and related appurtenances and facilities, including all related personal property (the “Improvements”), which are constructed or otherwise acquired by Seller within the property generally known as _____, and described on Exhibit A, attached hereto and incorporated herein by reference.

To have and to hold the same, unto the District, its successors and assigns forever, and Seller, for itself, its successors and assigns, covenants and agrees to and with the District, its successors and assigns, to warrant and defend the sale of said Improvements, hereby made unto the District, its successors and assigns, against all and every person or persons whomsoever, and warrants that the conveyance of the Improvements to the District, its successors and assigns, is made free from any claim or demand whatsoever.

The Seller further agrees and assures:

1. That all of the Improvements described herein were installed in substantial compliance with the District’s Rules and Regulations and applicable construction standards, and that said Improvements are in first-class working order, free from any defect whatever.
2. That no charges for materials or labor are due and payable on any of the Improvements described herein, and that Seller shall indemnify, defend, and hold the District and its agents, employees, engineers, and attorneys, harmless from and against all claims, damages, judgments, losses, and expenses of every nature, including reasonable attorney’s fees, arising at any time out of any act or omission of Seller and its employees, subcontractors and their employees, and all other persons directly or indirectly involved or performing work for Seller on the Improvements described herein.
3. If within two (2) years after the date of **Construction Acceptance** of the Improvements by the District, any Work is found to be defective, Seller shall promptly, without cost to the District and in accordance with the District’s written instructions, within seven (7) days after the District’s issuance of written instructions correct the defective Work at Seller’s cost. If Seller does not promptly comply with the terms of such instructions or in an emergency where delay would cause serious risk of loss or damage, the District may have the defective Work corrected or removed and replaced,

and all direct and indirect costs of such removal and replacement, including compensation for additional professional services, shall be paid by Seller. Seller shall also pay for any damage done to other work, other property or persons that occurred as a result of the defective Work within the **TWO-YEAR** warranty period.

4. Except for any notice required by law to be given in another manner, (a) any notice to Seller provided for in this Bill of Sale shall be in writing and shall be given and be effective upon (1) delivery to Seller or (2) mailing such notice by first class U.S. mail, addressed to Seller to Seller's address stated herein or at such other address as Seller may designate by notice to the District and (b) any notice to the District shall be in writing and shall be given and be effective upon (1) delivery to the District or (2) mailing such notice by first class U.S. mail, to the District's address stated herein or to such other address as the District may designate by notice.

IN WITNESS WHEREOF, the Seller has caused its name to be hereunto subscribed this _____ day of _____, 20__.

SELLER:

By: _____

(Title)

Mailing Address

STATE OF COLORADO)
) ss.
COUNTY OF EAGLE)

The foregoing instrument was acknowledged before me this _ day of _____, 20__, by _____ as _____ of _____.

WITNESS my hand and official seal.

(S E A L)

Notary Public

My commission expires: _____

SEWER EASEMENT

THIS EASEMENT is made this _____ day of _____, 20___, by and between _____ (hereinafter referred to as "Grantor"), and it's successors and assigns, and the **Eagle River Water and Sanitation District**, a quasi-municipal corporation of the State of Colorado within the County of Eagle, (hereinafter referred to as "District").

WITNESSETH, that for and in consideration of the sum of One Dollar (\$1.00) and other good and valuable consideration paid by the District to Grantor, the receipt of which is hereby acknowledged, the Grantor does hereby grant, convey and transfer unto the District, its successors and assigns, a perpetual easement and right to construct, install, remove, replace, add to, maintain, repair, operate, change or alter underground sewer lines and all underground and surface appurtenances related thereto such as lift stations and manholes (hereinafter "sewer lines"), together with any and all sewer lines situate therein, all necessary rights-of-way for convenient ingress and egress thereto and therefrom, and the right to occupy and use, from time to time, as much of the adjoining land of the Grantor as may be reasonably necessary for any of the aforesaid purposes, over, under and across the following described premises, situate in the County of Eagle, State of Colorado, to-wit:

See EXHIBIT A attached hereto and incorporated herein by reference.

Grantor warrants that the Grantor has the lawful right to grant and convey such easement, rights-of-way, and sewer lines. Further, Grantor warrants that the sewer lines are free and clear of all liens and encumbrances.

Grantor will at no time permit, place or construct any structure, building or improvement of any kind, temporary or permanent, on any part of the above-described premises. Any structure, building or improvement located on the above-described premises as of the date of this Easement, may be removed by the District without liability for damages arising therefrom.

Following the completion of the purpose of any entry by the District upon such easement for any of the aforesaid objects, the District shall restore the premises to substantially the same condition existing at the time of the entry thereon, except for shrubs, plants, sidewalks, driveways or parking areas thereon located or damaged thereby.

All provisions of the Easement, including all benefits and burdens, shall run with the land and shall be binding upon and inure to the benefit of the successors and assigns of the parties hereto, subject to the provisions hereof.

FORM D5: SEWER EASEMENT

IN WITNESS WHEREOF, the parties hereto have set their hands and seal the day and year first above written.

GRANTOR:

(Name of Grantor)

STATE OF COLORADO)
) ss.
COUNTY OF _____)

The foregoing Easement was subscribed and sworn to before me this _____ day of _____, 20__, by _____.

WITNESS my hand and official seal.

(S E A L)

Notary Public

My commission expires:

ACCEPTED by the District this _____ day of _____, 20__.

By: _____
General Manager

LENDER'S CONSENT

_____ Consents to the foregoing Easement and binds itself, its successors and assigns, the same as though its Deed of Trust, recorded on _____, 20__, at Reception Number _____ of the records of the Clerk and Recorder of _____ County, Colorado, was made specifically subject to said Easement.

By: _____
Title: _____

STATE OF COLORADO)
) ss.
COUNTY OF _____)

The foregoing Easement was subscribed and sworn to before me this _____ day of _____, 20__, by _____.

WITNESS my hand and official seal.

(S E A L)

Notary Public

My commission expires:

EXAMPLE SPECIFICATION
SECTION 01 70 00
WASTEWATER FLOW MANAGEMENT PLAN

PART 1 - GENERAL

1.1 SUMMARY

- A. Section Includes
 - 1. Planning and implementation of wastewater flow diversions.
- B. Related Sections include but are not necessarily limited to:
 - 1. Division 0
 - 2. Section 01 33 00 – Submittals.
 - 3. Section 01 35 05 – Environmental Protection and Special Controls.
 - 4. Section 01 73 00 – Discharge Emergency Response Plan.
- C. Completely coordinate with work of other trades.

1.2 QUALITY ASSURANCE

- A. Qualifications:
 - 1. The Sub-Contractor responsible for the Wastewater Flow Management Plan (WFMP) and bypass pumping is required to have three years of experience in wastewater flow management in a sewage interceptor or collection application.
- B. Referenced Standards:
 - 1. Uni-Bell Pipe Association
 - a. UNI-B-6-98, Recommended Practice for Low-Pressure Air Testing of Installed Sewer Pipe

1.3 SUBMITTALS

- A. Shop Drawings:
 - 1. See Specification Section 01 33 00 for the requirements for the mechanics and administration of the submittal process.
 - 2. Product technical data including:
 - a. Wastewater Flow Management Plan (WFMP): Detailed implementation plan.
 - b. Template of Communication/Documentation Plan.
 - 3. Submit WFMP a minimum of 30 days prior to work planned.
- B. Sub-Contractor Qualifications

1.4 WASTEWATER FLOW MANAGEMENT PLAN

- A. General: Submit to the Engineer a Wastewater Flow Management Plan for the portion of the wastewater collection system to be bypassed.
 - 1. Submit WFMP thirty (30) working days prior to implementation of flow diversion/bypass.
 - 2. Submit Draft WFMP submittals in electronic format (PDF) to allow expedited review.
 - 3. Include in WFMP the sequence of diversion operations, and all other operations the Contractor will establish to maintain wastewater conveyance during the diversion/bypass period.
 - a. Include as part of the WFMP, the monitoring procedures and frequencies.
 - b. Include as part of the WFMP, the maintenance procedures and frequency.
 - 4. Obtain approval of the WFMP from the Engineer/Owner at least five (5) working days prior to flow diversion/bypass.
 - 5. No deviation from the approved WFMP will be allowed without prior written approval.
- B. Include a Discharge Emergency Response Plan indicating the procedures, personnel, equipment, and activities that will be implemented in the event of a discharge, spill or overflow to the environment per Section 01 73 00.

- C. Observe and comply with all Federal, State, and local laws, ordinances, codes, orders, and regulations which in any manner affect the conduct of the work, specifically as they relate to discharges, spills, or overflows to the environment.
 - 1. The Contractor shall be fully responsible for preventing discharges, spills or overflows; containing discharges, spills or overflows; recovery and legal disposal of discharges, spills or overflows; any fines, penalties, claims and liability arising from negligent or willful discharge, spill or overflow, and violation of any law, ordinance, code, order, or regulation as a result of the discharge, spill or overflow.
 - 2. The Contractor shall be responsible for payment of any fines or penalties assessed against the Owner or Engineer for such discharges, spills, or overflows, including any attorney fees and costs associated with defending any action against the Owner or Engineer resulting from such discharges, spills or overflows.
- CI. Do not damage existing public and private improvements, interrupt existing services and/or facility operations which may cause a discharge, spill or overflow.
 - 1. Immediately repair any utility and/or improvement which is damaged by the Contractor at the expense of the Contractor.
- CII. The Contractor will be charged for all costs associated with the Owner's staff members' efforts if they are dispatched to the diversion system failure.
- CIII. Do not discharge any groundwater, storm water or hazardous waste encountered during the construction project to the sanitary sewer system without prior written approval of the Owner.
- CIV. Size the WFMP to handle the range of flows expected in the affected portion of the wastewater collection system. Work with the Owner and Engineer to determine the appropriate flow range.

PART 2 - PRODUCTS - (NOT USED)

PART 3 - EXECUTION

3.1 GRAVITY PIPING WITH BULKHEAD

- A. Submit to Engineer and Owner as part of the WFMP, at minimum, the following:
 - 1. Plan and profile view drawing, design details for the bulkhead(s), stop logs or stop plates, and pipe sizing.
 - a. Utilize an aerial photo depicting the location of the piping system for the plan view.
 - b. Include a capacity analysis to verify pipe capacity vs. peak flow.
 - 2. Include a start date, time and duration of diversion.
 - 3. Include all maintenance procedures and frequency
- B. After approval, install diversion system per plan.
- C. Inspect and maintain the diversion system daily.
- D. Drain residual wastewater from piping system to the sanitary sewer prior to disassembly, taking care to avoid wastewater spills.

3.2 BYPASS PUMPING EQUIPMENT

- A. Submit to Engineer and Owner, as part of the WFMP, a detailed bypass design including, but not limited to;

1. An aerial photo depicting pump/piping locations, bypass piping size(s), and a capacity analysis to verify pipe/pump capacity vs. design flows and procedures on inserting, securing and removing of plugs and “plug retrieval” devices, if used.
 2. Include a start date, time and duration of diversion.
- B. Use equipment (including plugs) inspected and found to be in good repair and fully functional.
1. Utilize equipment (including plugs) that does not leak during operation.
- C. Provide a pumping system consisting of pumps, pipe and generators.
1. Provide extra pumps and generators, with a total capacity equal to 100% of the maximum design flow must also be provided.
 - a. Provide a minimum of two pumps and generators on site.
 2. Operate the backup pumps and generator for a minimum of 25% of the total bypass time on a daily basis.
 3. Do not use bypass system until all pumps and generators are fully installed, operational, and ready for immediate use.
 4. Provide each pump with an isolation valve allowing removal and replacement if necessary during pumping operations.
- D. Use pressure-rated piping materials in good working condition.
- E. Hydrostatically pressure test diversion system in the presence of the Engineer using potable water prior to wastewater flow diversion.
1. Test pressure shall be 50% greater than maximum operating pressures, or 10 psi above maximum operating pressures, whichever is greater.
 2. Pressure test minimum duration: one half hour.
 - a. If any portion of the bypass piping is in a location that does not allow visual inspection for leaks, conduct an air test prior to the hydrostatic test.
 - 1) Perform air test in accordance with Uni-Bell Pipe Association UNI-B-6-98 and must pass.
 3. Demonstrate to the satisfaction of the Owner that both the primary and backup flow diversion systems are fully functional and adequate.
 - a. Demonstration shall include test-pumping a minimum of one hour at the daily peak flow period, in the presence of the Engineer.
 - b. Certify the same, in writing, to the Engineer.
- F. System Monitor
1. Dedicate a minimum of one person to the bypass pumping whose sole function/responsibility is to continuously monitor the operation of the pumps and the water level in the suction structure to detect any possible failure that may cause a wastewater discharge, spill or overflow to the environment, or diversion system failure.
 2. Provide a minimum of one qualified person on site at all times (24 hours a day 7 days a week) to monitor the system while bypass pumping operations are active.
- G. After approval of the WFMP, install diversion system per plan.
- H. Fuel Storage
1. Provide one dedicated fuel tank for every single pump/generator, if fuel/generator driven pumps are used.
 2. Provide a fuel level indicator outside each fuel tank.
 3. Continuously monitor the fuel level in the tanks and ensure that the fuel level does not drop below a level equivalent of two hours of continuous flow diversion system operation.
 4. Monitor all hoses and repair leaks immediately.
 5. Take the necessary measures to ensure the fuel supply is protected against contamination.
 - a. This could include but is not limited to fuel line water traps, fuel line filters, and protecting fuel stores from precipitation.
- I. Inspect and maintain the bypass system daily, including the back-up system

- J. In addition to the requirements above, the flow bypass shall have the following general minimum requirements:
 - 1. Provide and install pump controller panel.
 - 2. Provide and install floats for pump start/stop levels.
 - 3. Provide spare hoses at site.
 - 4. Provide at least two emergency generators at the site, each sized to operate the system.
- K. Drain residual wastewater from piping system to an approved sanitary sewer prior to disassembly, taking care to avoid wastewater spills.

3.3 COMMUNICATION/DOCUMENTATION

- A. Maintain a daily log of all inspection, maintenance and repair records, and provide weekly copies to the Engineer.

3.4 DISCHARGE/DIVERSION SYSTEM FAILURE

- A. In the event of a discharge, spill or overflow, or diversion/bypass system failure, immediately implement the Discharge Emergency Response Plan (See Section 01 73 00).

END OF SECTION

EXAMPLE SPECIFICATION
SECTION 01 73 00
DISCHARGE EMERGENCY RESPONSE PLAN

PART 1 - GENERAL

1.1 SUMMARY

- A. Section Includes:
 - 1. Development of a Discharge Emergency Response Plan, to be implemented in the event of a discharge, spill or overflow to the environment, or a diversion system failure, including loss of a plug.
- B. Related Sections include but are not necessarily limited to:
 - 1. Division 0
 - 2. Section 01 30 00 – Special Conditions.
 - 3. Section 01 33 00 – Submittals.
 - 4. Section 01 70 00 – Wastewater Flow Management Plan.

1.2 SUBMITTALS

- A. See Section 01 33 00 for requirements for the mechanics and administration of the submittal process.
- B. Product Data:
 - 1. Discharge Emergency Response Plan: Detailed implementation plan.

1.3 DISCHARGE EMERGENCY RESPONSE PLAN (DERP) DEVELOPMENT

- A. Develop and submit to the Engineer at least fifteen (15) working days prior to the start of construction at a site requiring flow management, a written Discharge Emergency Response Plan (DERP).
 - 1. Develop DERP to respond to any construction related discharge, spill or overflow to the environment or an event that could lead to a discharge, spill or overflow to the environment.
 - 2. The Contractor's DERP must not rely on the Owner's personnel for emergency response, but they may be dispatched, at the Owner's discretion, to provide additional assistance.
 - 3. Do not discharge any groundwater, storm water, or hazardous waste encountered during the construction project to the sanitary sewer system without prior written approval of the Owner.
- B. The DERP shall include at minimum, the following:
 - 1. Development of an emergency notification procedure that complies with state and federal requirements including but not limited to, Section 25-8-601(2), C.R.S.
 - a. Designate primary and secondary representatives, their respective phone numbers, and mobile phone numbers.
 - b. List Owner and Engineer contacts as well.
 - 2. Identification of personnel and equipment/tools that will be utilized in the event of a discharge, spill or overflow to the environment.
 - 3. Include an emergency response team with arrangements for backup personnel and equipment.
 - a. Provide emergency response team capable of mobilizing to the site 24 hours a day 7 days a week including weekends and holidays to respond immediately to any discharge, spill or overflow to the environment related to the Project work.
 - 4. Identification of storm inlets, manholes and waterways in the immediate project area.
 - 5. Step-by-step procedures to contain, control, and minimize discharges, spills or overflows to the environment.
 - 6. Cleanup procedures.

7. Typical plug search and retrieval procedures.
- C. At the pre-construction meeting, the Contractor will be provided with a list of Owner and Engineer representatives to contact in case of a discharge, spill, or overflow to the environment.
 1. Add these contacts to the DERP.
- D. Contractor cannot begin work on bypass pumping until the Engineer has approved the DERP in writing.
 1. Keep an approved copy of the DERP available on the job site at all times.
- E. It shall be the Contractor's responsibility to assure that all employees, including subcontractors, know and obey all emergency procedures included in the DERP.

PART 2 - PRODUCTS (NOT USED)

PART 3 - EXECUTION

3.1 DISCHARGE EVENT

- A. In the event of a discharge, spill, or overflow to the environment, or an event that could lead to a discharge, spill, or overflow to the environment:
 1. Immediately implement the DERP without direction from the Engineer or Owner, to control and contain the discharge, spill, or overflow to the environment.
 2. Contact Owner and Engineer immediately. Information to provide shall include at minimum, the following:
 - a. Location of discharge, spill, or overflow to the environment.
 - b. Estimated volume.
 - c. Time discharge, spill, or overflow began.
 - d. Duration if already terminated, or expected duration if in progress.
 - e. Cause (if known), if not known provide only the known facts.
 - f. Control measures implemented.
 - g. Type of remedial and/or clean up measures taken.
 - h. Description of affected or potentially affected sensitive areas such as waterways, channels, catch basins and entrances to existing underground storm drains.
 - i. Evidence of any environmental and/or human health impacts.
 3. Based on this information, the Engineer will determine if the discharge, spill or overflow is contained.
 4. If the discharge, spill or overflow is deemed reportable, draft a follow up report to regulatory agencies and submit to the Owner for review.
 - a. Submit draft within 3 working days and submit the final report by certified mail within 5 working days of the incident.
- B. Within two (2) working days of the discharge, spill or overflow, or other event prompting implementation of the DERP, submit to the Engineer and Owner a written Discharge Incident Report.
- C. The Engineer and Owner will evaluate the suggested procedural changes to avoid further discharges, spills, overflows or emergencies and will instruct the Contractor to revise the DERP and Wastewater Flow Management Plan (WFMP) if applicable to incorporate these changes.
 1. The Engineer and Owner may institute further corrective actions, as deemed necessary.
 2. Do not resume work at a site requiring flow management until the revised DERP and WFMP if applicable has been approved.
- D. Observe and comply with all Federal, State, and local laws, ordinances, codes, orders, and regulations which in any manner affect the conduct of the work, specifically as they relate to discharges, spills, or overflows to the environment.

1. The Contractor shall be fully responsible for preventing discharges, spills, or overflows to the environment, containing the discharges, spills or overflows, recovery and legal disposal of discharges, spills or overflows, any fines, penalties, claims and liability arising from negligent or willful discharge, spill or overflow, and violation of any law, ordinance, code, order, or regulation as a result of the discharge, spill or overflow.
 2. Pay any fines or penalties assessed against the Owner or Engineer for any such discharge, spill or overflow, including any attorney fees and costs associated with defending any action against Owner resulting from such discharge, spill or overflow.
- E. Do not damage existing public and private improvements, interrupt existing services and/or facility operations which may cause a discharge, spill or overflow to the environment.
1. Immediately repair any utility and/or improvement which is damaged by the Contractor at the expense of the Contractor.
- F. Once the discharge, spill or overflow has been contained and the situation causing the event has been stabilized, restore the affected areas to original condition, as soon as possible.

END OF SECTION

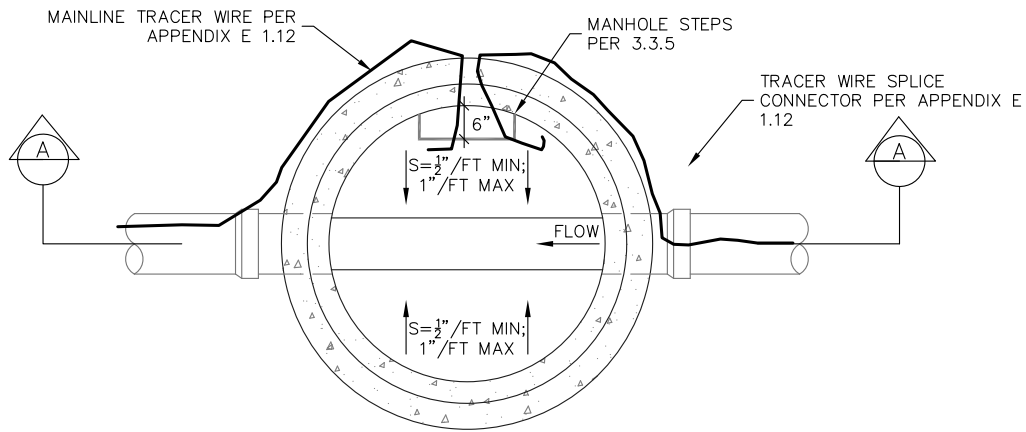

PLAN

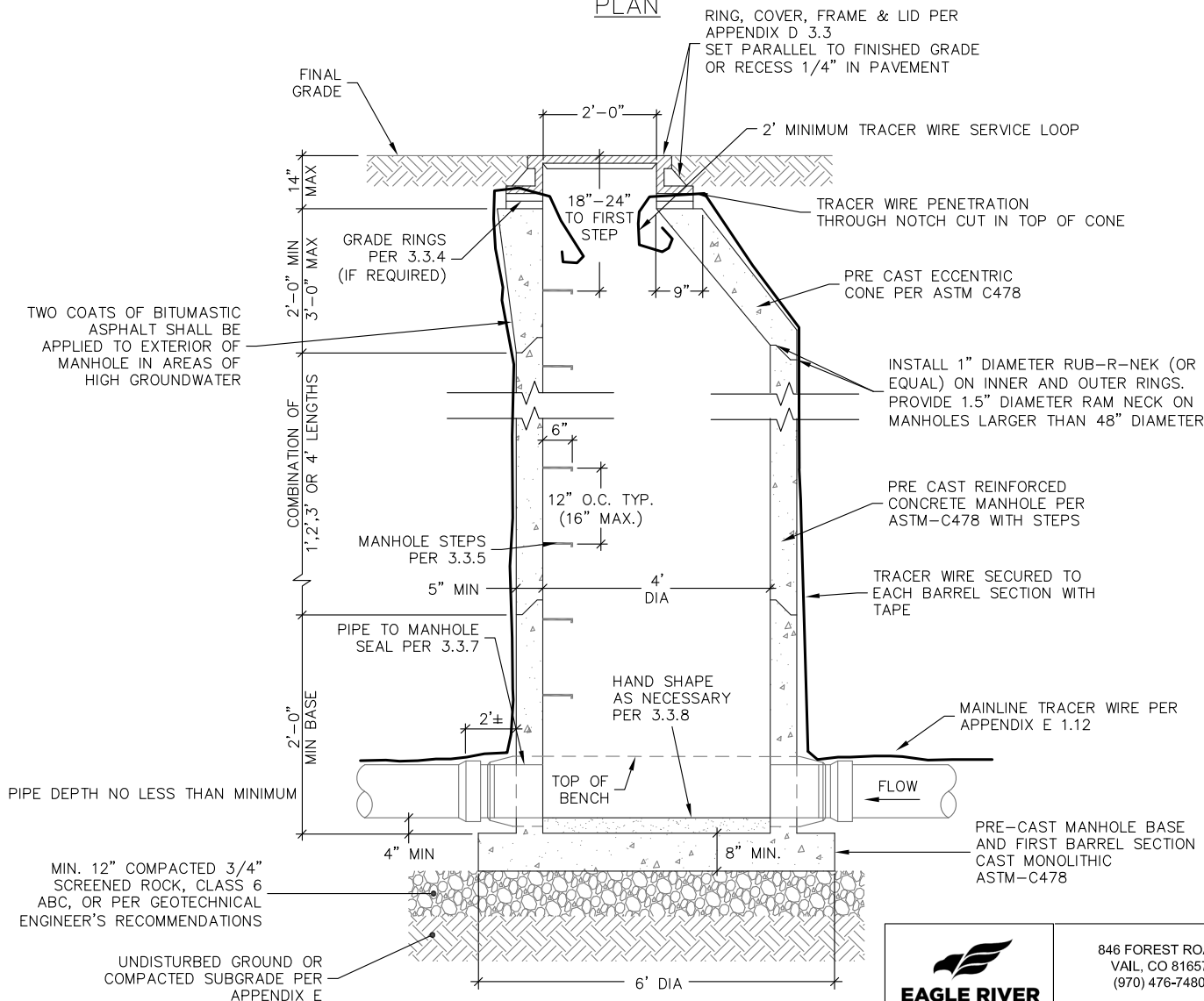

SECTION A

GENERAL NOTES

1. ALL CONCRETE WORK SHALL COMPLY WITH LATEST ACI-318 SPECIFICATIONS.
2. MANHOLE TROUGH SHALL HAVE A MINIMUM OF 0.2' DROP FROM ENTRANCE THROUGH EXIT.
3. FLOW CHANNEL TO BE SHAPED AS TO NOT ALLOW STANDING WATER PER 3.3.8.
4. MANHOLE SHALL CONFORM TO ASTM C478 AND ALL APPLICABLE DISTRICT STANDARDS (APPENDIX D).

 EAGLE RIVER WATER & SANITATION DISTRICT	846 FOREST ROAD VAIL, CO 81657 (970) 476-7480 WWW.ERWSD.ORG	
	STANDARD MANHOLE	
DRAWN BY: JEC	DATE: 03/01/2017	
SCALE: NONE	REV: 3/31/2023	
D-01		

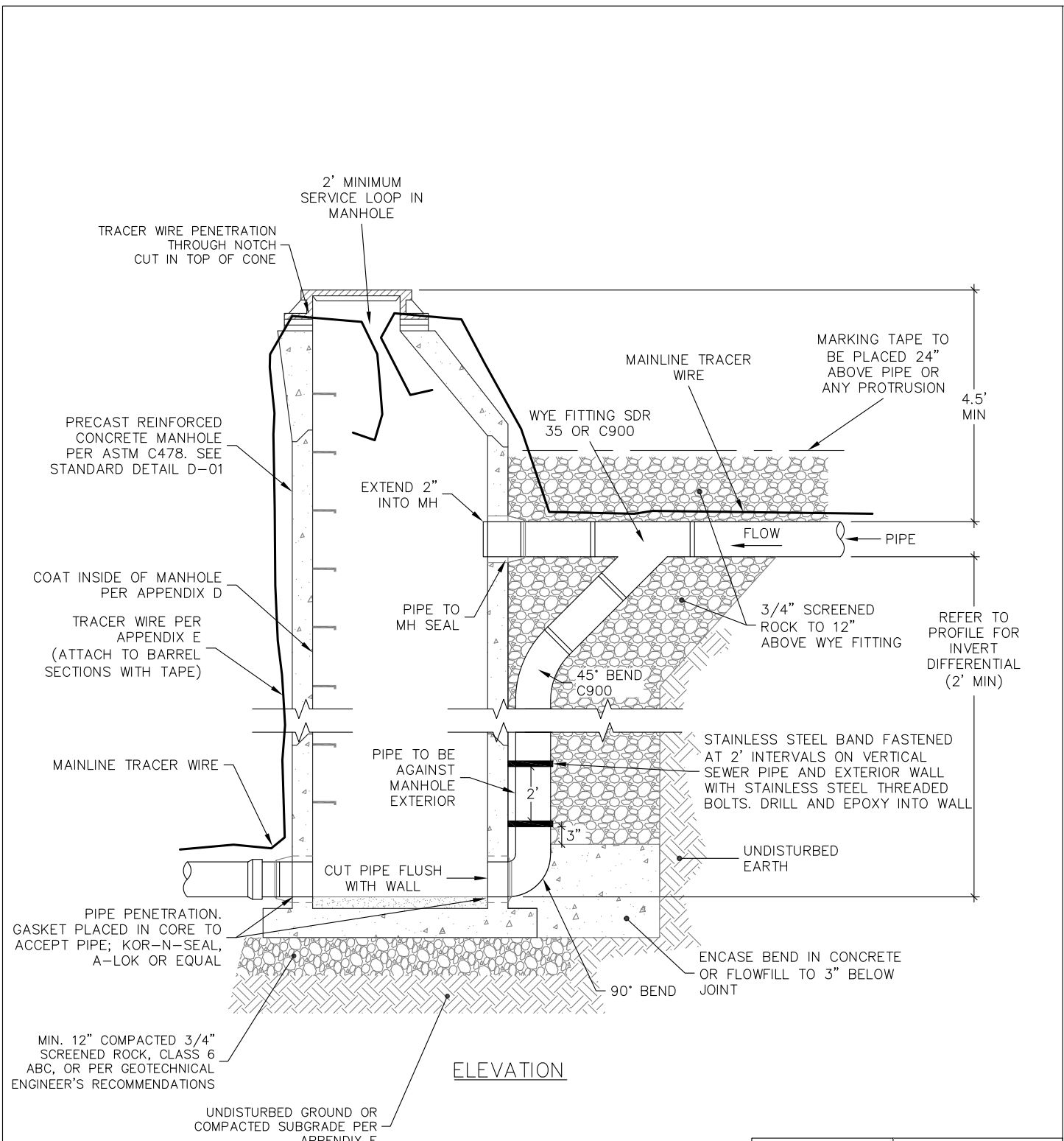

MIN. 12" COMPACTED 3/4" SCREENED ROCK, CLASS 6 ABC, OR PER GEOTECHNICAL ENGINEER'S RECOMMENDATIONS

UNDISTURBED GROUND OR COMPACTED SUBGRADE PER APPENDIX E

GENERAL NOTES

1. SEE 2.4.12 AND 3.3.11.
2. MANHOLE SHALL CONFORM TO D-01 STANDARD MANHOLE DETAIL AND ALL APPLICABLE DISTRICT STANDARDS.
3. ALL CONCRETE WORK SHALL COMPLY WITH LATEST ACI-318 SPECIFICATIONS.
4. MANHOLE TROUGH SHALL HAVE A MINIMUM OF 0.20' DROP FROM ENTRANCE THROUGH EXIT.

 <p>EAGLE RIVER WATER & SANITATION DISTRICT</p>	<p>846 FOREST ROAD VAL, CO 81657 (970) 476-7480 WWW.ERWSD.ORG</p>
<p>DROP MANHOLE CONNECTION</p>	
DRAWN BY: JEC	DATE: 03/01/2017
SCALE: NONE	REV: 3/31/2023
<p>D-02</p>	

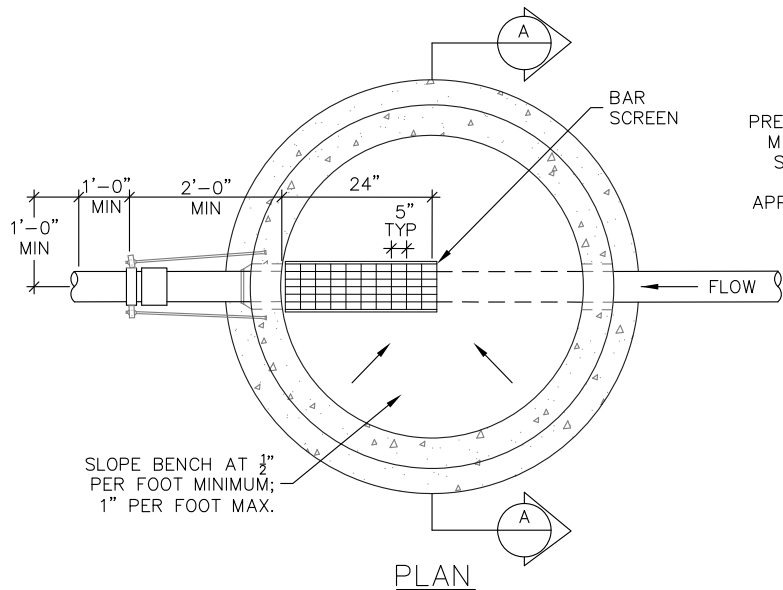

PRE CAST REINFORCED CONCRETE MANHOLE PER ASTM-C478 AND SHALL CONFORM TO STANDARD DETAIL D-01 AND ALL APPLICABLE DISTRICT STANDARDS

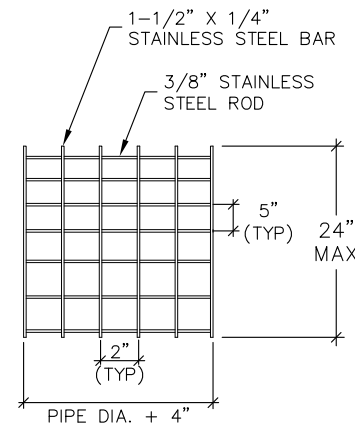
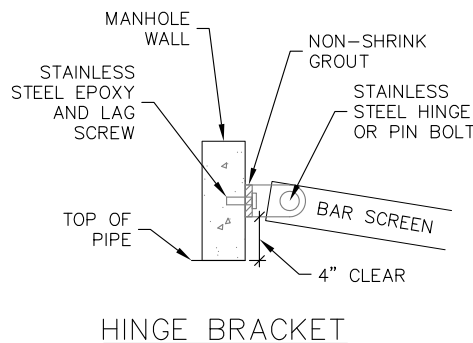
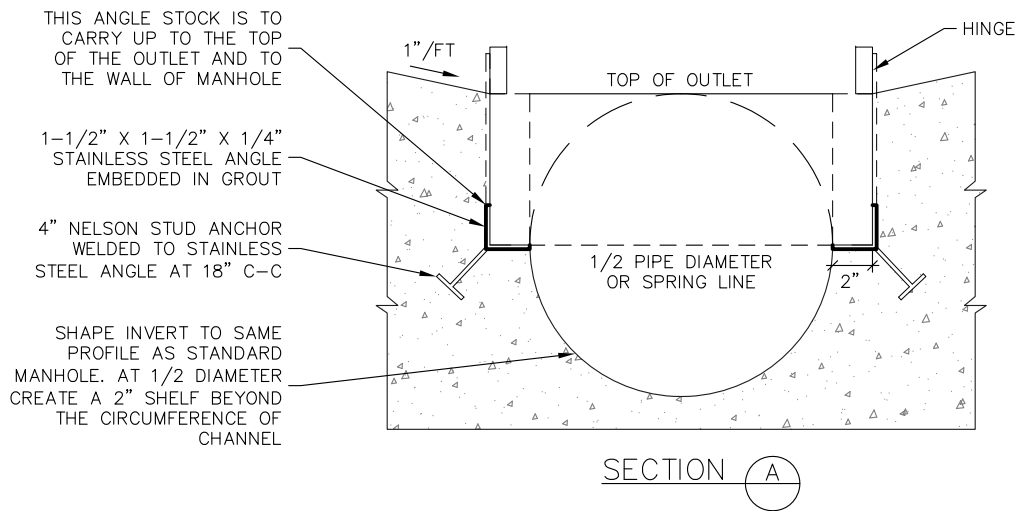
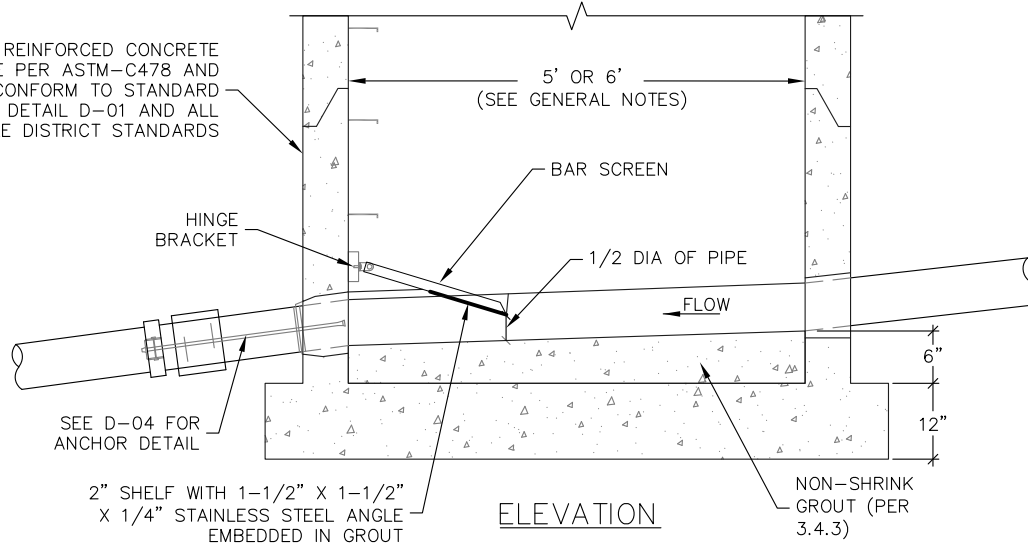

SECTION A

HINGE BRACKET

BAR SCREEN

GENERAL NOTES

- 5' DIAMETER MANHOLES SHALL BE ALLOWED FOR STRAIGHT THROUGH BAR SCREENS. SLOPE TO BE 0.25' MIN.
- 6' MANHOLES SHALL BE REQUIRED FOR 3-WAY AND/OR CHANGES OF DIRECTION. SLOPE TO BE 0.30' MIN.
- BAR SCREEN CHANNEL AND BENCH TO BE HAND SHAPED AND GRADED BY CONTRACTOR PER 3.3.8 AND 3.3.9. APPENDIX D.
- ALL HARDWARE FOR BAR SCREEN SHALL BE 316 STAINLESS STEEL.
- ALLOW CLEARANCE FOR BAR SCREEN TO SWING UP FOR CLEANING.
- CONCRETE BENCH FROM INLET TO OUTLET TO BE EQUAL TO PIPE DIAMETER. FORM A BENCH TO SLOPE UP AT 5% TO WALLS OF MANHOLE AS REQUIRED FOR A STANDARD MANHOLE.
- FORM A 2" SUB-BENCH ON EITHER SIDE OF CHANNEL AND FOLLOW SAME SLOPE AS BAR SCREEN. EMBED 1-1/2" X 1-1/2" X 1/4" ANGLES ALONG THIS BENCH FOR REST.

BAR SCREEN TO BE 24" LONG AND THE WIDTH IS TO BE DIAMETER OF PIPE + 4". 1-1/2" X 1/4" STOCK SHALL FORM THE LONG AXIS OF THE SCREEN AND 3/8" ROD SHALL FORM THE BARS

 <p>EAGLE RIVER WATER & SANITATION DISTRICT</p>	<p>BAR SCREEN MANHOLE AND DETAILS</p>	
	<p>DRAWN BY: JEC</p>	<p>DATE: 03/01/2017</p>
<p>846 FOREST ROAD VAIL, CO 81657 (970) 476-7480</p>	<p>SCALE: NONE</p>	<p>REV: N/A</p>
<p>WWW.ERWSD.ORG</p>		<p>D-03</p>

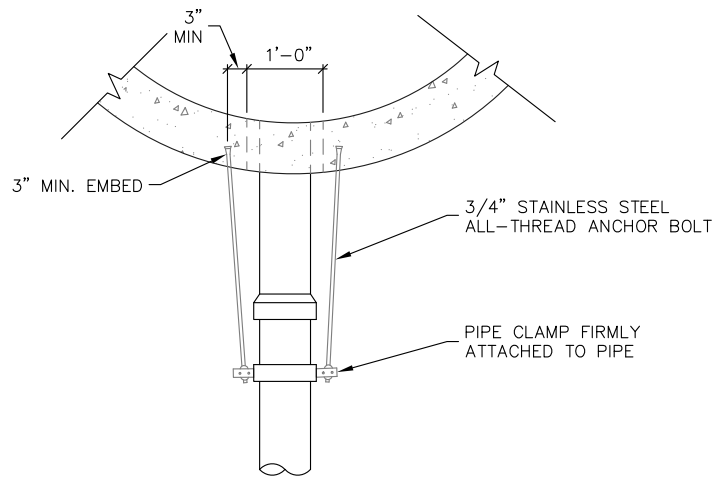

TOP VIEW

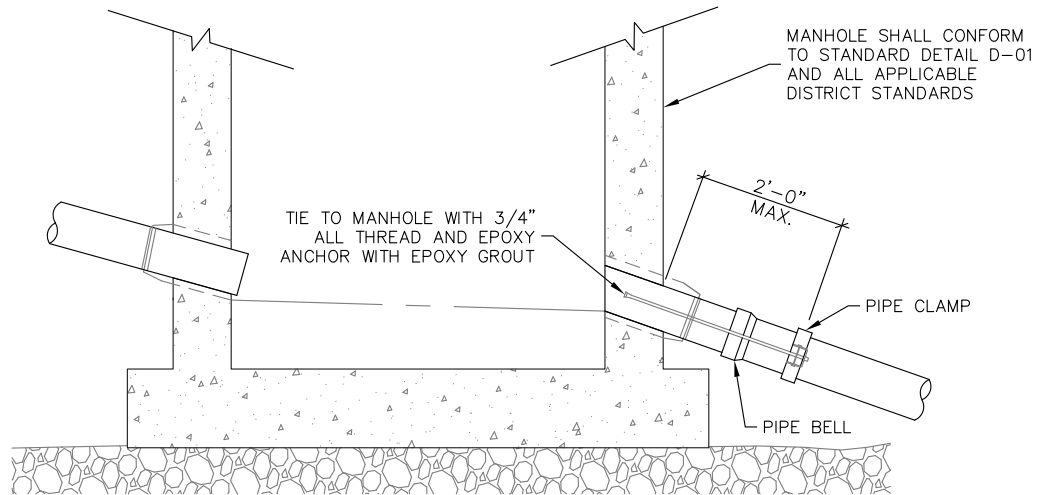

ELEVATION

GENERAL NOTES

1. ANCHOR MANHOLES ARE REQUIRED WHERE PIPE SLOPE EXCEEDS 20% EXITING THE MANHOLE ONLY. PER APPENDIX D.
2. SEWER MAINS ON 20 PERCENT SLOPES OR GREATER SHALL BE ANCHORED SECURELY WITH CONCRETE ANCHORS SPACED AS FOLLOWS:
 - a. NOT OVER 36 FEET CENTER TO CENTER ON GRADES 20 PERCENT AND UP TO 35 PERCENT
 - b. NOT OVER 24 FEET CENTER TO CENTER ON GRADES 35 PERCENT AND UP TO 50 PERCENT
 - c. NOT OVER 16 FEET CENTER TO CENTER ON GRADES 50 PERCENT AND OVER.

	846 FOREST ROAD VAIL, CO 81657 (970) 476-7480 WWW.ERWSD.ORG	
	ANCHOR MANHOLE	
DRAWN BY: JEC	DATE: 03/01/2017	
SCALE: NONE	REV: N/A	
D-04		

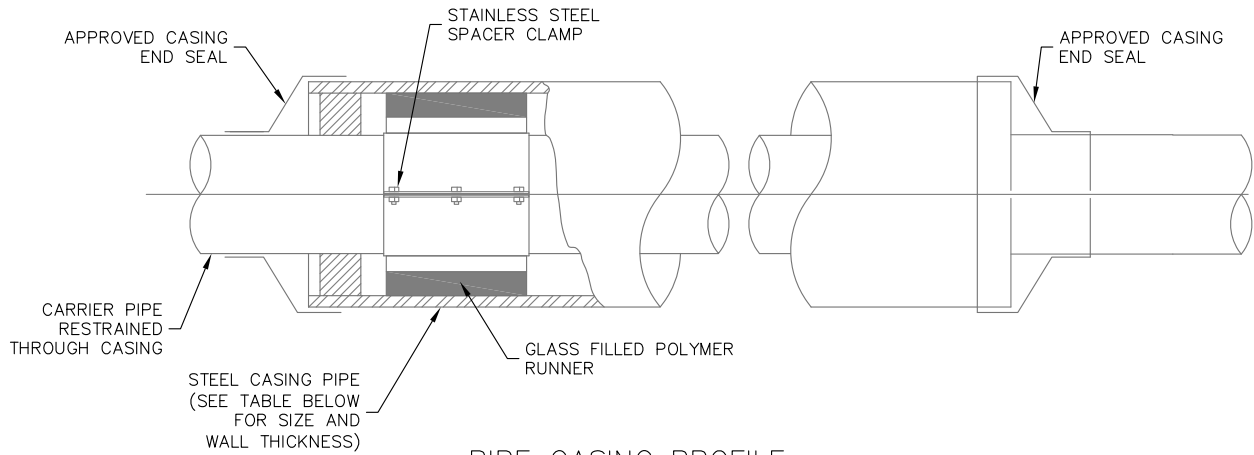

CASING MATERIAL, SEALS AND SPACERS PER 3.7 APPENDIX D

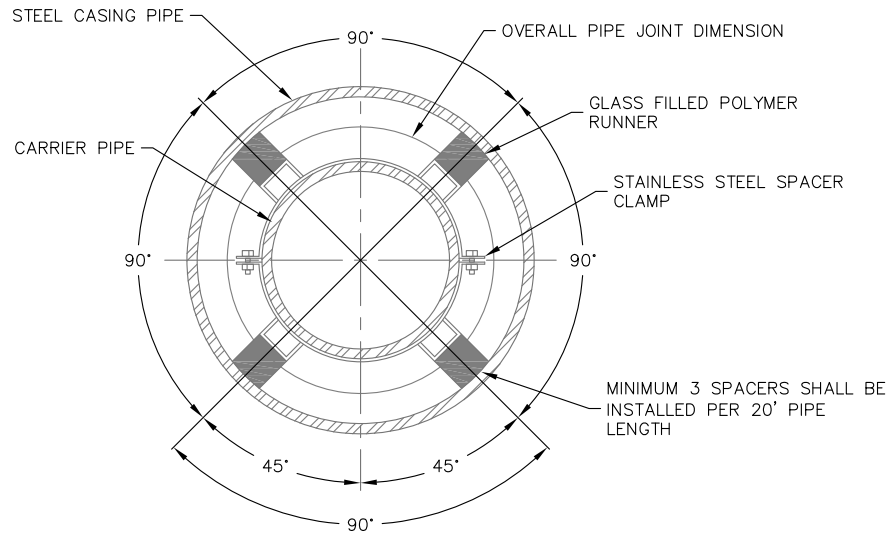

GENERAL NOTES

1. FOLLOW MANUFACTURER'S RECOMMENDATION, IF IN CONFLICT WITH ERWSD STANDARDS, USE MORE RESTRICTIVE SPECIFICATION.
2. CARRIER PIPE SHALL BE CENTERED AND ALL JOINTS RESTRAINED IN & THROUGH THE CASING PIPE.
3. SEWER MAINS SHALL BE ENCASED SEPARATELY FROM OTHER UTILITIES.
4. ALL FASTENERS SHALL BE T-304 STAINLESS STEEL.
5. MAXIMUM DISTANCE BETWEEN SPACERS SHALL BE 6 FEET ON CENTER.

CARRIER PIPE NOMINAL Ø	CASING PIPE	
	MIN OD	MIN WALL THICKNESS
4"	12"	0.25"
6"	16"	0.3125"
8"	18"	0.3125"
12"	22"	0.375"
16"	28"	0.500"
20"	32"	0.500"

	846 FOREST ROAD VAIL, CO 81657 (970) 476-7480 WWW.ERWSD.ORG	
	SEWER MAIN CASING DETAIL	
DRAWN BY: JEC	DATE: 03/01/2017	
SCALE: NONE	REV: N/A	
D-05		

CONSTRUCT HAMMERHEAD OR 90° SIDEARM
TURNAROUND AT THE END OF ALL DEAD END
SEWER LINES. SEE STANDARD DETAIL D-08

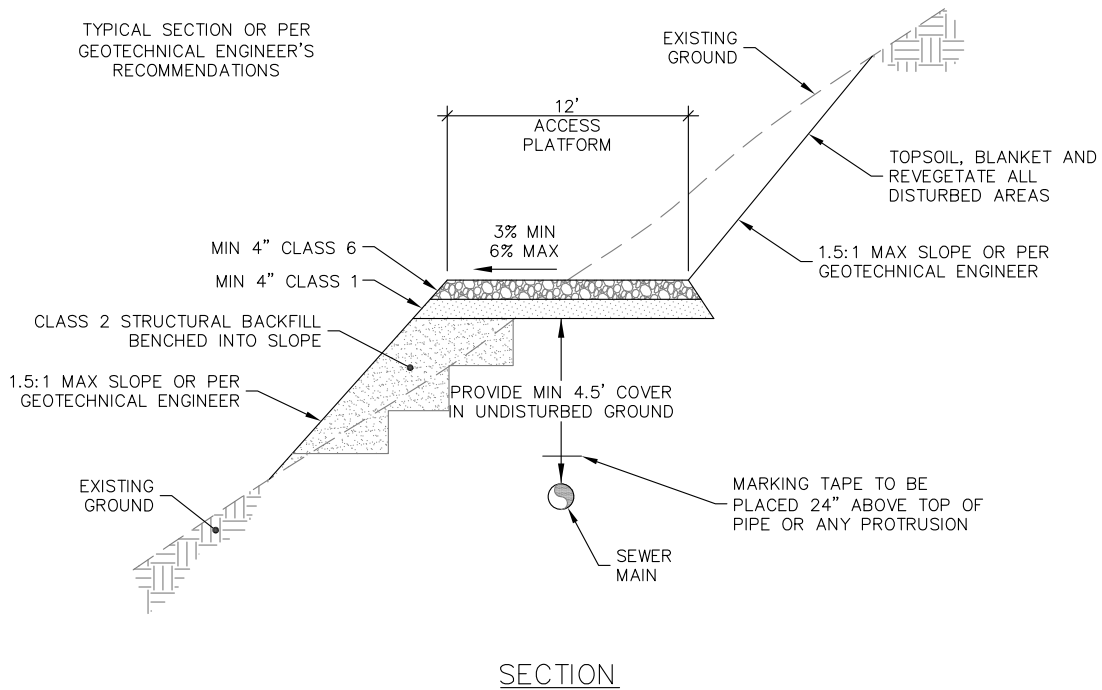

GENERAL NOTES

1. THE CONTRACTOR SHALL GRADE ALL OFF ROAD SEWER LINE TRENCHES TO PROVIDE ACCESS PLATFORM.
2. ACCESS PLATFORMS SHALL BE GRADED TO MATCH ROAD GRADES TO PROVIDE VEHICULAR ACCESS AT ALL ROAD AND PLATFORM ACCESS INTERSECTIONS. MAXIMUM GRADE FOR BACK LOT ACCESS SHALL BE 10%.
3. ALL EARTHWORK SHALL BE IN CONFORMANCE WITH APPENDIX E.
4. TOPSOIL, BLANKET AND REVEGETATE ALL DISTURBED AREAS.

	846 FOREST ROAD VAIL, CO 81657 (970) 476-7480
	WWW.ERWSD.ORG
BACKLOT SEWER MAINTENANCE ACCESS	
DRAWN BY: JEC	DATE: 03/01/2017
SCALE: NONE	REV: N/A
D-06	

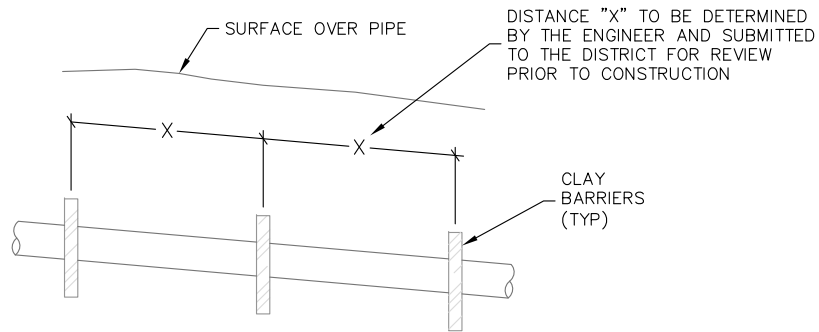
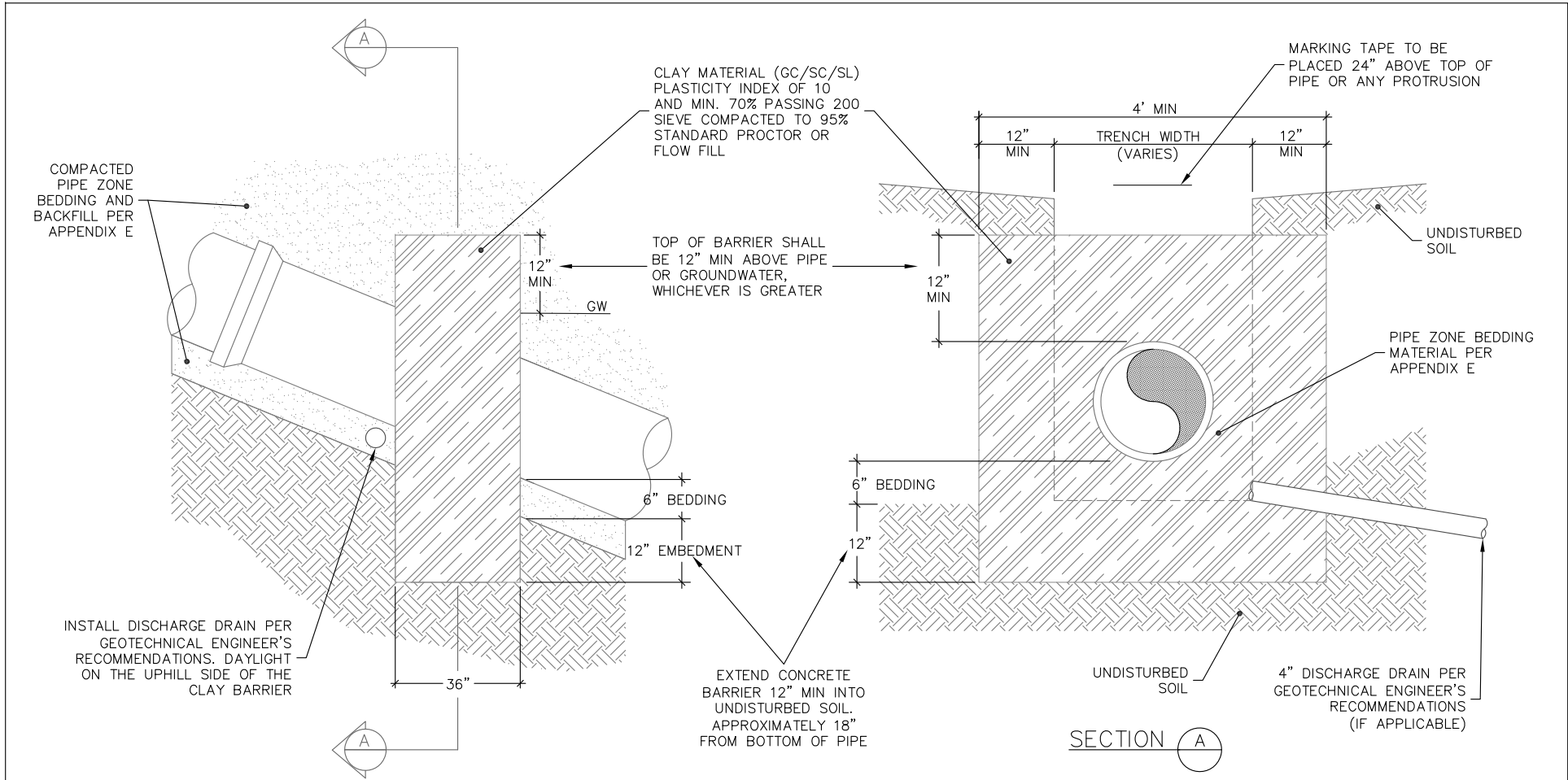

ELEVATION

 EAGLE RIVER WATER & SANITATION DISTRICT	GROUNDWATER BARRIER	
	DRAWN BY: JEC	DATE: 03/01/2017
846 FOREST ROAD VAIL, CO 81657 (970) 476-7480 WWW.ERWSD.ORG	SCALE: NONE	REV: N/A
D-07		

BACK LOT EASEMENT TURNAROUND
SIDE 90° ARM DESIGN

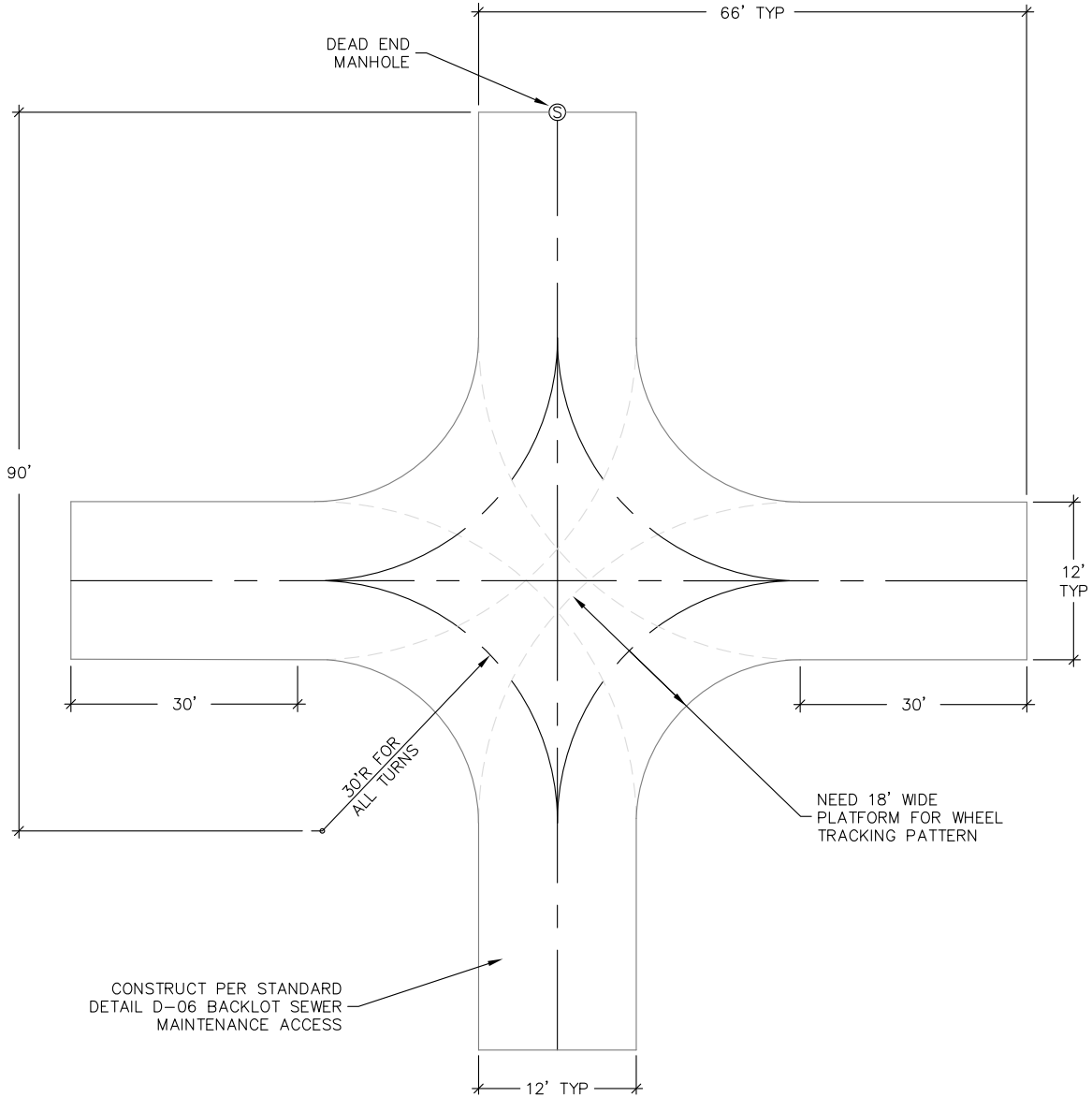

CONSTRUCT PER STANDARD
DETAIL D-06 BACKLOT SEWER
MAINTENANCE ACCESS

NEED 18' WIDE
PLATFORM FOR WHEEL
TRACKING PATTERN

30'R FOR
ALL TURNS

GENERAL NOTES

1. DIMENSIONS INDICATE REQUIRED USEABLE PLATFORM AND DO NOT INCLUDE CUT OR FILL SLOPES.
2. 90° ARM CAN BE EITHER RIGHT OR LEFT SIDE.
3. TURN AROUNDS MAY BE INSTALLED AS TERRAIN DICTATES AND AS APPROVED BY THE DISTRICT.
4. BACK LOT MAINTENANCE ACCESS & TURNAROUNDS MUST BE ENTIRELY LOCATED WITHIN DEDICATED EASEMENTS.

	846 FOREST ROAD VAIL, CO 81657 (970) 476-7480 WWW.ERWSD.ORG	
	SIDE 90° ARM DESIGN TURNAROUND	
DRAWN BY: JEC	DATE: 03/01/2017	
SCALE: NONE	REV: N/A	
D-08		

SEWER PIPE COVER DEPTH	MINIMUM EASEMENT WIDTH REQUIRED
4'6" TO 8'6"	20'
8'7" TO 11'0"	25'
11'1" TO 13'6"	30'
13'7" TO 16'0"	35'
16'1" TO 18'6"	40'
18'7" TO 21'0"	45'
21'1" TO 23'6"	50'

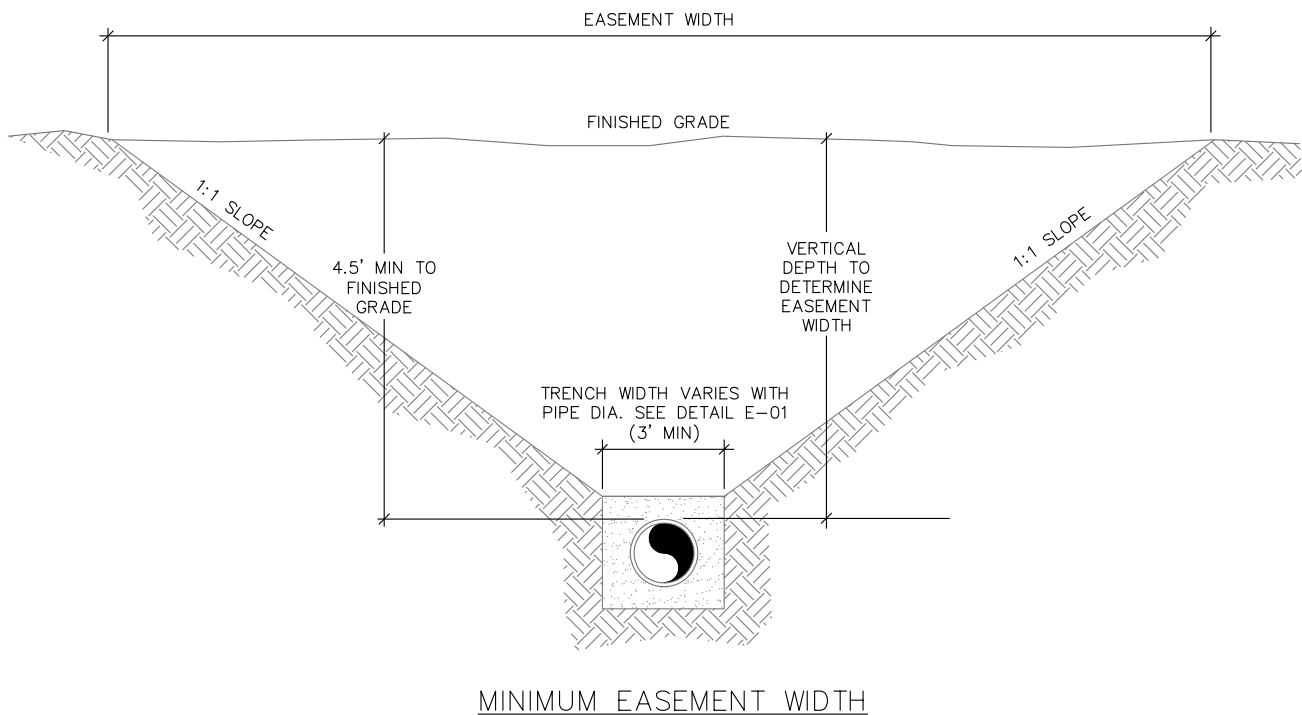

GENERAL NOTES

1. PIPE SHALL BE CENTERED IN EASEMENT.
2. ANY PROPOSED SEWER MAIN DEPTH GREATER THAN 14' DEEP REQUIRES AN ALTERNATIVES ANALYSIS AND DISTRICT APPROVAL.
3. CALCULATE EASEMENT WIDTH AS FOLLOWS:
 $W = \text{DEPTH TO TOP OF PIPE} \times 2 + 3 \text{ FEET}$
 (ROUNDED UP IN 5 FOOT INCREMENTS)

EXAMPLE:
 10 FOOT DEEP PIPE = $10 \times 2 + 3 = 23 \text{ FEET}$
 $W = 25 \text{ FOOT WIDE EASEMENT ROUNDED}$

	846 FOREST ROAD VAIL, CO 81657 (970) 476-7480 WWW.ERWSD.ORG	
	EASEMENT WIDTH DETAIL	
DRAWN BY: JEC	DATE: 03/01/2017	
SCALE: NONE	REV: N/A	
D-09		

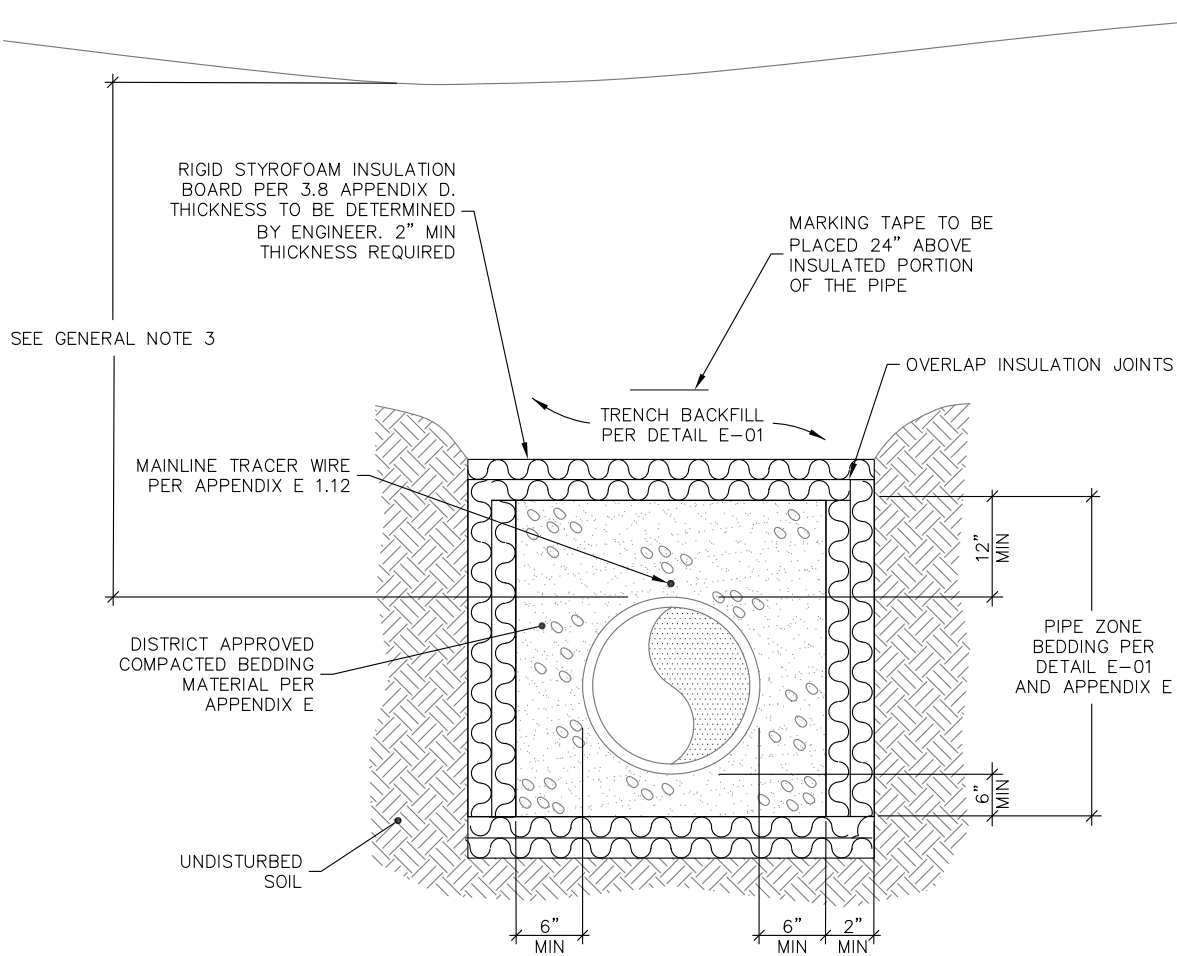

ELEVATION

GENERAL NOTES

1. CONDITION OF LESS THAN MINIMUM BURY DEPTH IS ALLOWED ONLY WITH WRITTEN APPROVAL FROM THE DISTRICT PRIOR TO CONSTRUCTION. INSULATION SHALL BE INSTALLED ON ALL PIPE THAT DOES NOT MEET MINIMUM BURY REQUIREMENTS.
2. THE USE OF INSULATION MUST BE APPROVED BY THE DISTRICT PRIOR TO INSTALLATION.
3. INSULATION SHALL BE INSTALLED ON ALL PIPES THAT DO NOT HAVE A MINIMUM OF 4.5' OF EFFECTIVE COVER. EFFECTIVE COVER SHALL BE DEFINED AS SEPARATION FROM COLD AIR SOURCES, INCLUDING STORM SEWERS. 1" OF INSULATION BOARD MAY BE SUBSTITUTED FOR EACH 1' OF SOIL COVER (MINIMUM 2" OF INSULATION) REQUIRED TO MEET THE MINIMUM COVER REQUIREMENT.
4. INSULATION SHALL BE DOW HIGHLOAD 100, OWENS CORNING FOAMULAR 1000, OR APPROVED EQUAL. HIGH COMPRESSIVE STRENGTH FOAM BOARD INSULATION IS REQUIRED WITHIN ALL RIGHT OF WAY AND PAVED AREAS.

 EAGLE RIVER WATER & SANITATION DISTRICT	846 FOREST ROAD VAIL, CO 81657 (970) 476-7480 WWW.ERWSD.ORG
	SEWER PIPE INSULATION DETAIL
DRAWN BY: JEC	DATE: 03/01/2017
SCALE: NONE	REV: 1/21/2020
D-10	

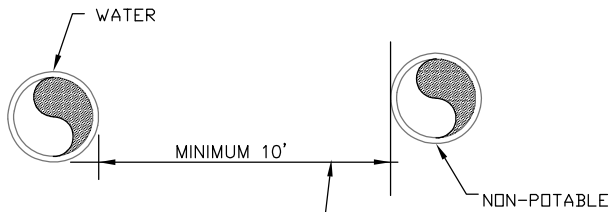

WATER PIPES MUST BE LAID AT LEAST 10 FEET HORIZONTALLY FROM ANY EXISTING OR PROPOSED NON-POTABLE PIPE (E.G. WASTEWATER PIPE, RAW WATER PIPE, STORM SEWER PIPE, SEPTIC TANK, OR SUBSOIL TREATMENT SYSTEM) EDGE TO EDGE.

REQUIRED SEPARATION FOR PARALLEL INSTALLATIONS

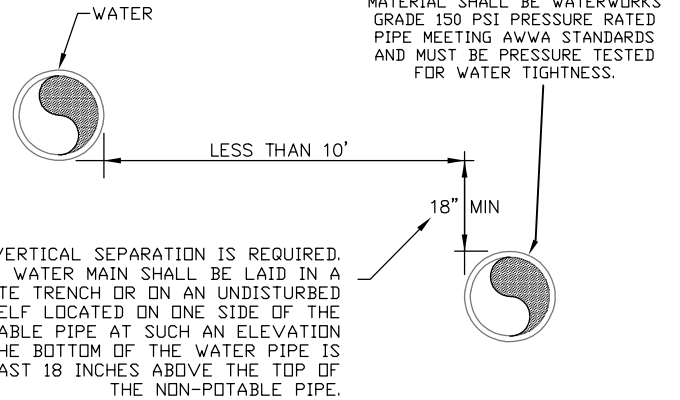

18" VERTICAL SEPARATION IS REQUIRED. THE WATER MAIN SHALL BE LAID IN A SEPARATE TRENCH OR ON AN UNDISTURBED EARTH SHELF LOCATED ON ONE SIDE OF THE NON-POTABLE PIPE AT SUCH AN ELEVATION THAT THE BOTTOM OF THE WATER PIPE IS AT LEAST 18 INCHES ABOVE THE TOP OF THE NON-POTABLE PIPE.

EXCEPTION- REQUIREMENTS FOR PARALLEL INSTALLATION WHEN SEPARATION CANNOT BE ACHIEVED

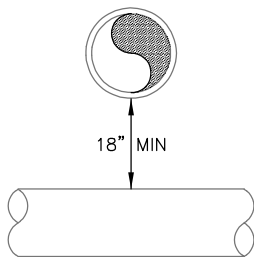

WATER PIPES CROSSING ANY NON-POTABLE PIPES MUST BE LAID TO PROVIDE A MINIMUM VERTICAL DISTANCE OF 18" BETWEEN THE OUTSIDE OF THE WATER PIPE AND THE OUTSIDE OF THE NON-POTABLE PIPE. IT IS PREFERRED THAT THE WATER PIPE BE ABOVE THE NON-POTABLE PIPE.

REQUIRED SEPARATION FOR PERPENDICULAR INSTALLATIONS

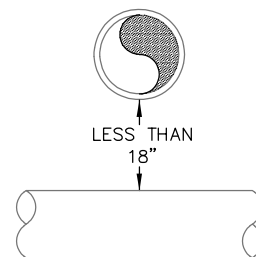

INSTALL SECONDARY CONTAINMENT ON EITHER THE WATER OR NON-POTABLE PIPE (WITH PREFERENCE ON THE NON-POTABLE PIPE). INSTALL PIPE CASING EXTENDING NO LESS THAN 9- FEET ON EACH SIDE OF THE CROSSING OR FLOWABLE FILL ENCASUREMENT EXTENDING NO LESS THAN 10 FEET EACH SIDE OF THE CROSSING. SEE GENERAL NOTES 3,4&5.

EXCEPTION- REQUIREMENTS FOR PERPENDICULAR INSTALLATIONS WHEN SEPARATION CAN NOT BE ACHIEVED

GENERAL NOTES

1. WATER PIPES MUST NOT PASS THROUGH OR COME IN CONTACT WITH ANY PART OF A WASTEWATER MANHOLE. WATER MAINS SHALL BE LOCATED A MINIMUM OF 10 FEET FROM A WASTEWATER MANHOLE (EDGE TO EDGE).
2. PIPE SEPARATION MUST COMPLY WITH THE STATE OF COLORADO DESIGN CRITERIA FOR POTABLE WATER SYSTEMS, SECTION 8.8 (ALL DETAILS REGARDING SEPARATION BETWEEN WATER AND WASTEWATER) OR THE MOST RECENT STATE OF COLORADO DESIGN CRITERIA.
3. SECONDARY CONTAINMENT- PIPE CASING OR CONCRETE/CONTROLLED LOW STRENGTH MATERIAL (EX. FLOWABLE FILL) MAY BE USED AS MEANS OF SECONDARY CONTAINMENT.
4. PIPE CASINGS MUST BE A SINGLE SECTION OF WATER TIGHT MATERIAL WITH NO JOINTS. THE CASING PIPE MATERIALS MAY BE STEEL, DUCTILE IRON, FIBERGLASS, FIBERGLASS REINFORCED POLYMER MORTAR (FRPM), OR POLYVINYLCHLORIDE (PVC) WITH SUITABLE CARRIER SUPPORTS AND CASING PIPE END SEALS. THE DESIGN MUST INCLUDE A MEANS TO SUPPORT THE INTERCEPTOR OR WASTEWATER MAIN TO PREVENT SETTLEMENT AND PERMIT MAINTENANCE OF THE WATER MAIN WITHOUT DAMAGE TO THE WASTEWATER PIPE.
5. CROSSINGS INVOLVING JOINTLESS PIPE SUCH AS HDPE, FUSIBLE PVC OR WELDED STEEL DO NOT REQUIRE INSTALLATION OF SECONDARY CONTAINMENT.

	846 FOREST ROAD VAIL, CO 81657 (970) 476-7480 WWW.ERWSD.ORG
	WATER & WASTEWATER SEPARATION
DRAWN BY: JEC	DATE: 03/01/2017
SCALE: NONE	REV: ICT 05/29/2024
D-11	

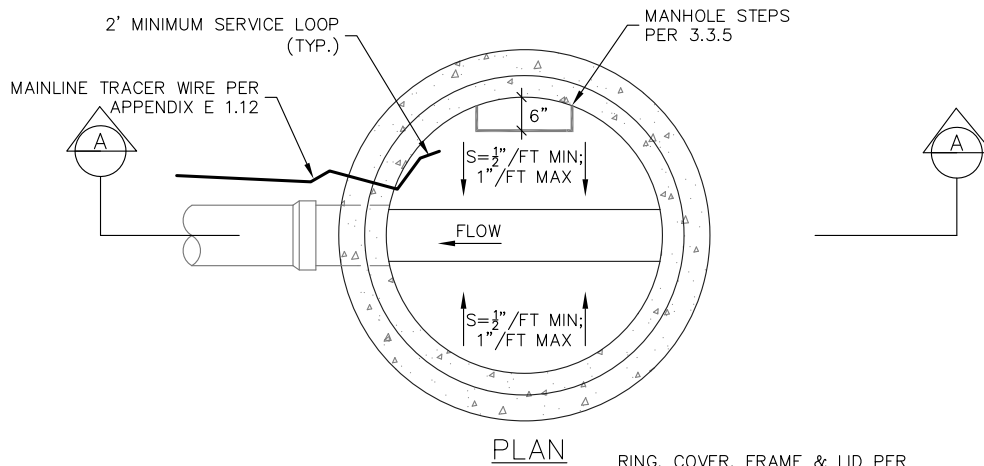

PLAN

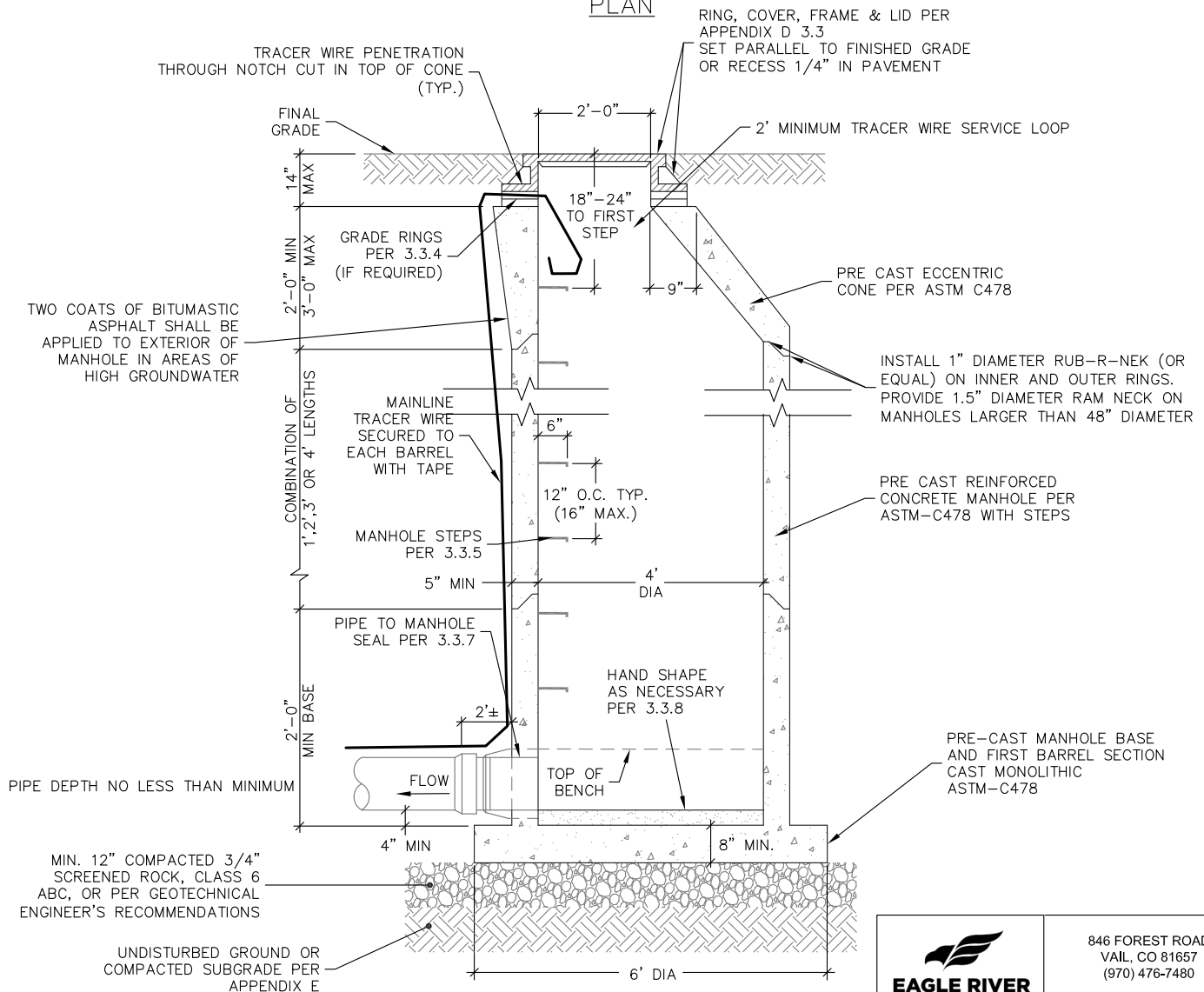

SECTION A

GENERAL NOTES

1. ALL CONCRETE WORK SHALL COMPLY WITH LATEST ACI-318 SPECIFICATIONS.
2. FLOW CHANNEL TO BE SHAPED AS TO NOT ALLOW STANDING WATER PER 3.3.8.
3. MANHOLE SHALL CONFORM TO ASTM C478 AND ALL APPLICABLE DISTRICT STANDARDS (APPENDIX D).

	846 FOREST ROAD VAIL, CO 81657 (970) 476-7480 WWW.ERWSD.ORG	
	DEAD END MANHOLE	
DRAWN BY: JRS	DATE: 1/21/2020	
SCALE: NONE	REV: 4/11/2023	
D-12		